

KENSAL

High Output Boiler Stoves



Instructions for Use, Installation & Servicing

For use in GB & IE (Great Britain & Republic of Ireland).

IMPORTANT

THE OUTER CASING, FRONT AND GLASS PANEL BECOME EXTREMELY HOT DURING OPERATION AND WILL RESULT IN SERIOUS INJURY AND BURNS IF TOUCHED. IT IS THEREFORE RECOMMENDED THAT A FIREGUARD COMPLYING WITH BS 8423 (LATEST EDITION) IS USED IN THE PRESENCE OF YOUNG CHILDREN, THE ELDERLY OR INFIRM.

Do not attempt to burn rubbish in this appliance.

Please read these Instructions carefully before installation or use.

Keep them in a safe place for future reference and when servicing the fire.

The commissioning sheet found on page 3 of these instructions should be completed by the Installer.

Contents

Kensal 40/60 - High Output Boiler Stoves

Covering the following models:

KEN40HBMF2/ KEN60HBMF2/ KEN60HBW2

Appliance Commissioning Checklist	3
User Instructions	4
Getting Started	4
User Instructions	7
Care & Maintenance.....	12
Troubleshooting	16
Installation Instructions	18
Installation Checklist.....	18
Pre-Installation Instructions	22
Installing the Appliance.....	25
Commissioning.....	30
Maintenance & Servicing	32
Technical Appendix	36
Information Requirement - Solid Fuel	40
Spare Parts List.....	40
Service Records	43



To receive your Extended Warranty your Kensal appliance must have been purchased from our Expert Retailer Network and registered within one month of purchase or installation. Please note that all warranties are effective from the date of purchase. Any Kensal product purchased outside of our Extended Retailer Network, or not registered within the stated time will carry a standard 12 month warranty.

It is a condition of the Extended Warranty that the installation complies with the relevant Building Regulations and is carried out by a suitably trained and qualified individual (HETAS in the UK or equivalent in other countries) with the certificate of installation and the Commissioning Report on Page 3 completed and retained by the end user.

Full terms and conditions are detailed in the Warranty Statement on the Kensal website www.kensalstoves.com. In the event of any conflict of information the wording on the website shall prevail.

Important Note: Should any problems be experienced with your product, claims must first be submitted to the Expert Retailer where the appliance was purchased from who will offer immediate assistance or contact Kensal on your behalf.

DESIGN PROTECTION

The technical details of this product are protected under UK Patent Application No GB2495920A

Appliance Commissioning Checklist

To assist us in any guarantee claim please complete the following information:-

Retailer appliance was purchased from:

Name:

Address:

Telephone number:

Essential information - MUST be completed:

Date Installed:

Model Description:

Serial Number:

Installation Engineer:

Company Name:

Address:

Telephone number:

Commissioning Checks - to be completed and signed:

Thermostat fitted	YES <input type="checkbox"/>	NO <input type="checkbox"/>
Is flue system correct for the appliance	YES <input type="checkbox"/>	NO <input type="checkbox"/>
Flue swept and soundness test complete	YES <input type="checkbox"/>	NO <input type="checkbox"/>
Smoke test completed on installed appliance	YES <input type="checkbox"/>	NO <input type="checkbox"/>
Spillage test completed	YES <input type="checkbox"/>	NO <input type="checkbox"/>
Use of appliance and operation of controls explained	YES <input type="checkbox"/>	NO <input type="checkbox"/>
Clearance to combustible materials checked	YES <input type="checkbox"/>	NO <input type="checkbox"/>
Instruction book handed to customer	YES <input type="checkbox"/>	NO <input type="checkbox"/>
Corrosion Inhibitor Added to Water System	YES <input type="checkbox"/>	NO <input type="checkbox"/>
Hot Water System Commissioned	YES <input type="checkbox"/>	NO <input type="checkbox"/>
CO Alarm Fitted	YES <input type="checkbox"/>	NO <input type="checkbox"/>

Signature: Print Name:

Getting Started

Welcome

Congratulations on purchasing your Kensal Boiler, if installed correctly Kensal hope it will give you many years of warmth and pleasure for which it was designed.

The purpose of this manual is to familiarise you with your appliance, and give guidelines for its installation, operation and maintenance. If, after reading, you need further information, please do not hesitate to contact your Kensal retailer.

1. General Points



IMPORTANT - DO NOT RUN THIS APPLIANCE WITHOUT ANY WATER IN THE SYSTEM OR IF IT IS SUSPECTED THE PIPES ARE FROZEN

- 1.1 Before installation and/or use of this appliance please read these instructions fully and carefully to ensure that you have fully understood their requirements.

The appliance must be fitted by a registered installer*, or approved by your local building control officer.

- 1.2 All local regulations, including those referring to national and European Standards need to be complied with when installing the appliance.
- 1.3 Only use for domestic heating. To achieve the optimum performance from this appliance it must be installed and operated according to these instructions burning the fuels recommended.
- 1.4 You must burn only approved fuels. Do not use with liquid fuels or as an incinerator.
- 1.5 Appliance surfaces become very hot when in use. Use a suitable fireguard[‡] if young children, elderly or infirm persons are present. Stovax offer firescreens, sparkguards and hearthgate systems for protection. Your Kensal Retailer can advise you about these products.
- 1.6 Do not place photographs, TV's, paintings, porcelain or other combustible items on the wall or near the appliance. Exposure to hot temperatures will cause damage. Do not place furniture or other items such as drying clothing closer than 1m from the front of this appliance.

WARNING: Extra fuel should not be stored on or next to the appliance. Only keep enough fuel for immediate use nearby and never leave the appliance unattended for long periods with any combustible material in close proximity.

- 1.7 Extractor fans or cooker hoods must not be placed in the same room or space as this can cause appliance to emit fumes into the room.



‡In the U.K. these products must conform to the latest edition of BS 8423, Fireguards for use with solid fuel appliances.

If appliance is operating unattended they must conform to the latest edition of BS 3248

***Registered on the Competent Persons Scheme (GB only see page 39/ INFO (Republic of Ireland)).**

- 1.8 Do not obstruct inside or outside ventilation required for the safe use of this appliance.
- 1.9 Do not make unauthorised changes to the appliance.
- 1.10 The chimney must be swept at least once a year. See Section 13.
- 1.11 Do not connect, or share, the same flue or chimney system with another appliance.
- 1.12 **This appliance is designed to be used with the doors shut.**



THERMOSTAT

This appliance is designed to be controlled by a thermostat which regulates the rate fuel is burnt and the amount of heat produced to hot water. A trial and error approach will establish settings to suit personal preference.

For Installation details refer to the instructions (PM747) supplied with the thermostat kit.

The thermostat controls the Primary Air into the appliance. The Primary Air Controls must be closed in order for the thermostat to operate correctly and efficiently.

The Primary Air Controls should only be used for short periods during initial lighting if required.

SERIAL NUMBER

- 1.13 This number is required when ordering spare parts or making warranty claims. It is found on the appliance data plate.

All models

For all models the data plate is found under the front of the appliance ashlip, see Diagram 1.

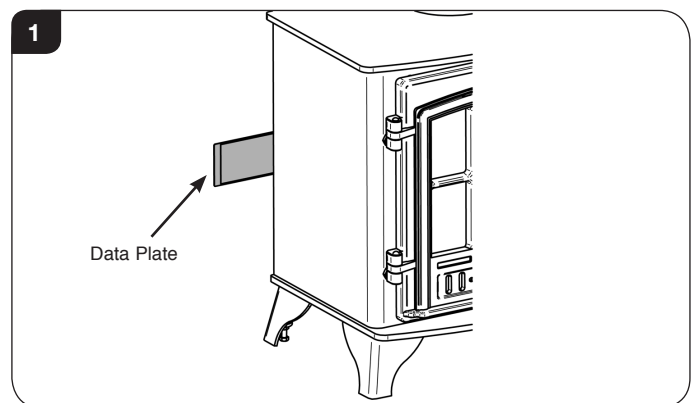

- 1.14 This appliance gives out its heat in two ways:

— Directly into the room in which it is fitted through convection and radiation.

— Hot water to heat radiators and domestic hot water. The output to hot water varies depending on how quickly the fuel is being burnt. For more detail see the graphs on page 20.

Getting Started

AIR CONTROLS

Triple Air Systems

Several Kensal appliances have triple air systems providing cleaner burning, and greater efficiency and control, see Diagram 2.

- 1) **Airwash** - air drawn over the window cleans the glass. The source of Primary Combustion air when burning wood.
- 2) **Primary Air** - for use initially when establishing fires and the main air supply when burning solid fuels.
- 3) **Cleanburn** - Secondary air is preheated through a heat exchanger to combust unburned hydrocarbons, providing a cleaner and more efficient burn.

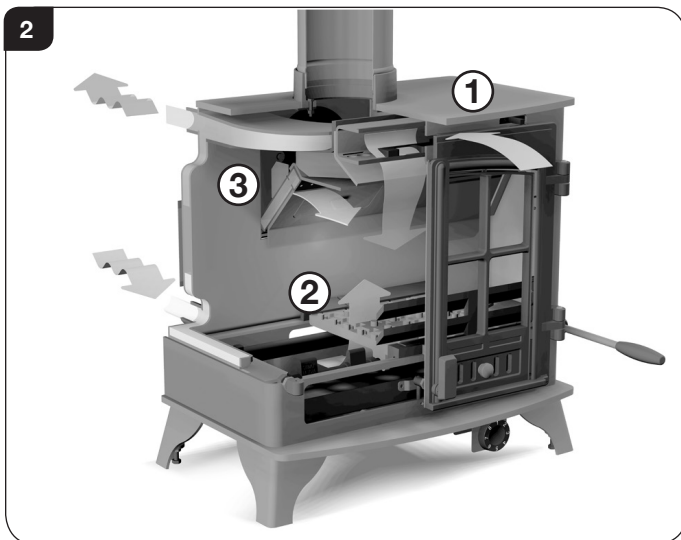

Manually operate the following air controls using a gloved hand or the tool provided.

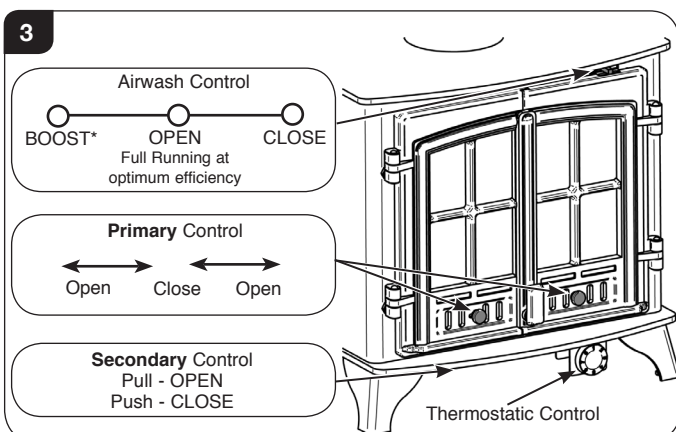

* The **boost setting** allows for quicker start up and glass cleaning only. DO NOT run the appliance on this setting for extended periods of time.

The **Secondary Air Control** is located below the appliance door, under the ashlip. This control is used to adjust the amount of 'Cleanburn' combustion air injected into the burning flames. Push air control in to reduce and pull to increase the flow of air.

DOOR HANDLE

IMPORTANT: Kensal provide gauntlet style gloves for the users protection from heat and any sharp edges when using the appliance. For your safety ensure that gloves are always worn when opening, operating, refuelling or handling internal metalwork.

Use a protected gloved hand to operate.

DO NOT OPEN THE DOOR WITH BARE HANDS

DO NOT OPEN THE DOORS WHEN THE FIREBOX IS FULL OF FLAMES - WAIT FOR THEM TO DIE DOWN.

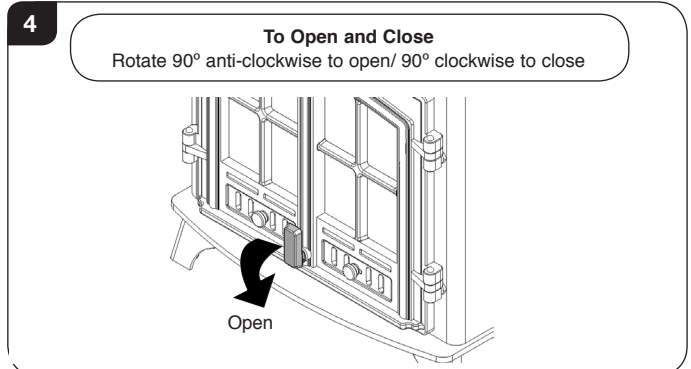

HEATING & HOT WATER SYSTEM CONTROLS

CONTROLS, GENERAL

- 1.15 As part of the installation of this appliance controls will have been fitted to the heating and hot water system in order to provide two functions:

- To control the comfort level in the house, see 1.16.
- To maintain safety in the event of misuse or mechanical failure, see 1.18.

COMFORT CONTROLS

- 1.16 A programmable timer switches the pump on when heat is required and off when it is not.

The timer, when combined with a room thermostat and / or thermostatic radiator valves, enhances the comfort levels in the house.

Some room thermostats combine the function with the timer and can be programmed to reduce the room temperature rather than turning the system off. This is effective in not allowing rooms to become too cold and speeding up recovery time.

- 1.17 The hot water cylinder can also be fitted with a thermostatic valve which turns off the flow when the cylinder has reached the desired temperature, but the heat leak radiator will have to be bigger to cope with the extra load when the tank is isolated.

Getting Started

SAFETY CONTROLS

- 1.18 A high limit thermostat is fitted to the gravity flow pipe set at 80°C. This thermostat should be connected to the pump so that the pump is turned on if the temperature exceeds 80°C. This will prevent accidental boiling in the gravity circuit.
- 1.19 It is also recommended to fit a low limit thermostat on the central heating return set at 45°C. This thermostat will turn the pump off if the return temperature falls below 45°C. This will prevent corrosion and condensation within the appliance.

NOTE – Further information on solid fuel central heating systems can be found in the HETAS engineers training manual.

WARNING



Properly installed, operated and maintained, this appliance will not emit fumes into the room. Occasional fumes from de-ashing and refuelling may occur.

Persistent fume emission is potentially dangerous and must not be tolerated.

If fume emission does persist:

- Open doors and windows to ventilate the room.
- Leave the room.
- Allow fire to burn out and safely dispose of fuel from the appliance.
- Check for chimney blockage and clean if required.
- Do not attempt to relight until the cause of the emission has been identified and corrected.
- If necessary seek expert advice.
- All open flued appliances can be affected by temporary atmospheric conditions which may allow fumes to enter the house. Because of this an electronic carbon monoxide detector conforming to the latest edition of BSEN50292 must be fitted in the same room as the appliance. The existence of an alarm must not be considered a substitute for ensuring regular servicing and maintenance of the appliance and chimney system.

IF THE ALARM SOUNDS FOLLOW THE INSTRUCTIONS GIVEN ABOVE.

2. Using the Appliance for the First Time

- 2.1 To allow the appliance to settle, and fixing glues and paint to fully cure, operate the appliance at a low temperature for first few days.
- 2.2 Do not touch the paint during the first period of use.
- 2.3 During this time the appliance may give off some unpleasant odours. Keep the room well ventilated to avoid a build-up of fumes.
- 2.4 Please be aware that, during use, rope seals may discolour. This is normal.

CONDENSATION

CAUTION WHEN FILLING

- 2.5 When filling the boiler with water for the first time, the cold water entering the water jacket can cause condensation to form on the surfaces of the appliance (inside and outside).
- 2.6 In certain conditions this condensation could result in a considerable amount of water, in some cases enough to fill the bottom of the appliance. This could be even worse if the house has recently been re-decorated, wet plastered or any other work has been undertaken which could result in high humidity.
- 2.7 Precautions must be taken to ensure that this build up of condensate does not overflow from the appliance onto any surrounding fabric of the room e.g. carpets.

NOTE - THIS CONDENSATION IS NORMAL DURING FILLING AND DOES NOT INDICATE A FAULTY OR LEAKING APPLIANCE.

NORMAL RUNNING

- 2.8 During normal running this condensation should be minimal if the system is fitted with the low limit thermostat as detailed in 1.19. This low limit thermostat prevents the system pump from running until the appliance has reached temperature.

SEASONAL USE

- 2.9 If this appliance is unused for lengthy periods of time it should be periodically checked to ensure that condensation is not building up within the appliance.

NOTE – THIS CONDENSATION IS NORMAL AND DOES NOT INDICATE A FAULTY OR LEAKING APPLIANCE.

If the appliance is going to be unused for very long periods of time it is recommended to drain the system.

User Instructions

3. Recommended Fuels

3.1 Wood Logs:

Burn only seasoned timber with a moisture content of less than 20%. To ensure this allow cut wood to dry for 12 to 18 months.

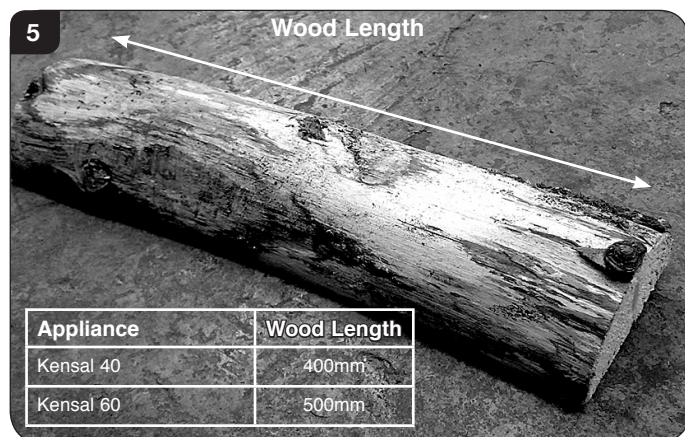

Poor quality timber:

- Causes low combustion efficiency
- Produces harmful condensation
- Reduces effectiveness of the airwash and life of the appliance

Do not burn construction timber, painted, impregnated / treated wood, manufactured board products or pallet wood.

3.2 Solid fuel:

— Burn only anthracite or manufactured briquette smokeless fuels listed as suitable for use with closed heating appliances.

Do not burn bituminous coal, 'petro-coke' or other petroleum based fuels as this will invalidate the product guarantee.

3.3 Fuel consumption.

As tested at nominal heat output to the requirements of EN 13240: 2001 for intermittent operation:

Description	Fuel Consumption	
	Kg/hour Wood	Kg/hour Briquette Smokeless fuel
Kensal 40	4.4	2.3
Kensal 60	5.8	2.9

HETAS Approval

Please note that HETAS Appliance Approval only covers the use of manufactured briquette smokeless fuels on these appliances. HETAS approval does not cover the use of other fuels either alone or mixed with the recommended fuels, nor does it cover instructions for the use of other fuels.

3.4 For advice on suitable solid fuels contact your local approved coal merchant*.

A number of factors can affect the performance of the appliance. See *Troubleshooting Section* for details.

4. Lighting the Appliance

i **IMPORTANT:** Kensal provide gauntlet style gloves for the users protection from heat and any sharp edges when using the appliance. For your safety ensure that gloves are always worn when opening, operating, refuelling or handling internal metalwork.

4.1 Whether using wood or solid fuel the process for lighting the appliance is the same.

4.2 For best results manually set air controls as shown in Diagram 6.

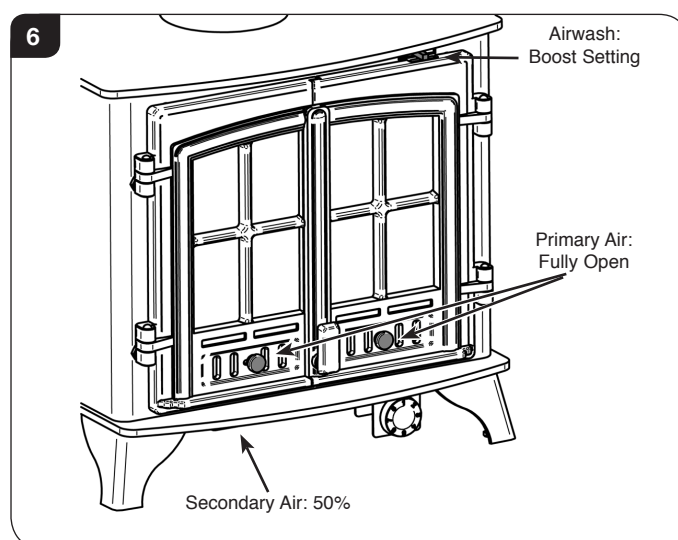

4.3 Place firelighters, or paper, and dry kindling wood on the grate (Multi-fuel version) or woodburning tray (Woodburning version).

A successful fire initially requires plenty of kindling to establish a hot firebox and warm the chimney to aid flue performance.

4.4 Light the paper or firelighters, see Diagram 7.



i ***In the U.K.:**

- Ring the Solid Fuel Association advice line on 0845 601 4406 for details
- Visit their web site at www.solidfuel.co.uk

User Instructions

- 4.5 Leave the door slightly open as the fire establishes and the glass warms to avoid build up of condensation.
- 4.6 Add larger pieces of wood.
Do not use full sized logs at this stage, build up gradually in size. Too many logs may smother the fire.

Do not load fuel above the log guard and the base of the baffle at the back of the firebox, see Diagram 8.

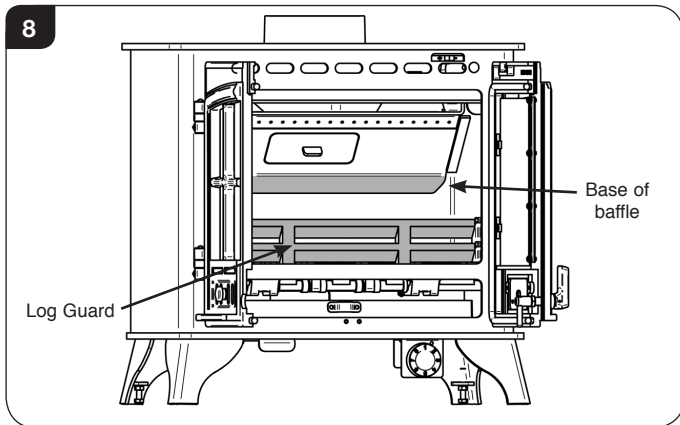

—Close the door.

Do not run with the door slightly open except for initial lighting as this could cause over-firing and damage the appliance.

Once the fire is established close the Primary Air Controls and set the thermostat to the desired temperature.

5. Running the Appliance

- 5.1 Only for use with recommended fuels, see *Section 3* for full details.
- For Woodburning Stoves, see Section 5a.
 - For Multi-fuel Stoves, see Section 5b.

5a. Woodburning Stove

This section applies to the following models:

- **Woodburning models** - pre fitted with a Woodburning tray.
- **Multi-fuel models** - Converted to burn Wood only by fitting an additional Woodburning tray, see Section 6.

DO NOT BURN SOLID FUEL ON A WOODBURNING TRAY AS THIS MAY CAUSE PERMANENT DAMAGE.

FOR CLARITY, THE FOLLOWING DIAGRAM DOES NOT INCLUDE ILLUSTRATIONS OF THE DOORS.

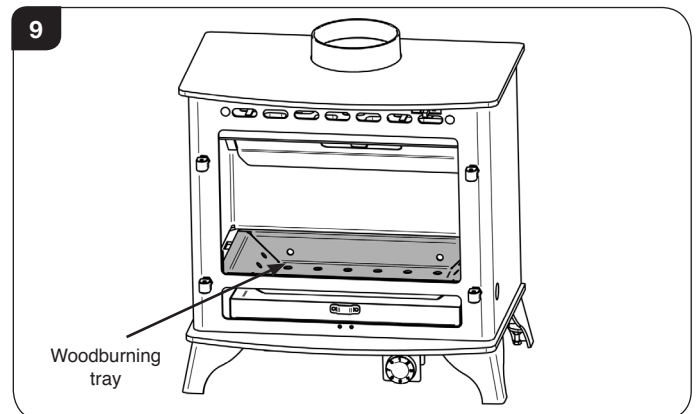

Wood burns best on a bed of ash (approx. 25mm (1") deep).

- 5.2 Rake the embers evenly over the firebed and open the **Airwash Control** fully for a few minutes before re-fuelling.
- 5.3 **Do not refuel when a large amount of flames are present in the firebox as this could cause smoke or flames to spill into the room.**
- 5.4 Add the correct amount of fuel, see Section 3.
- 5.5 **Close the doors immediately after refuelling.**
- 5.6 Burn new logs at a high temperature for a few minutes before adjusting the **Airwash Control**. Refuel little and often for clean, efficient burning. More Airwash will increase the heat output, burn fuel more quickly and will help keep the glass clean.

User Instructions

Manually operate the following air controls using a gloved hand or the tool provided.

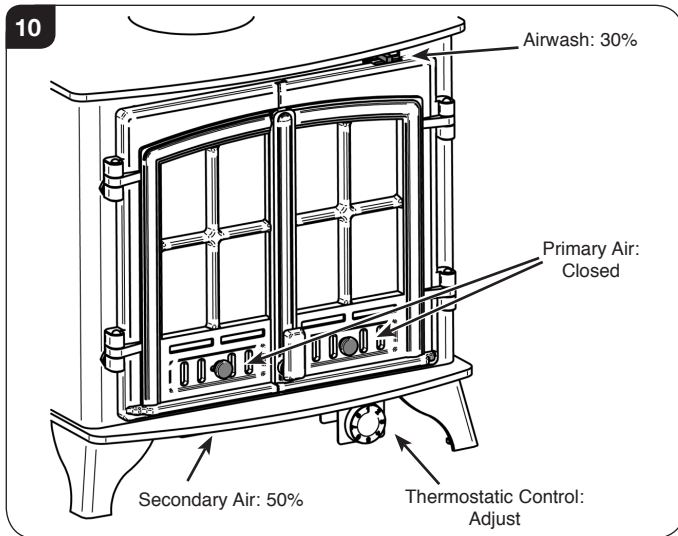

- 5.7 Close the **Primary Air Controls** and adjust the **Airwash Control** to approximately 30% open.
- 5.8 Adjust the Secondary Air Control to approximately 50% Open.
- 5.9 Control the temperature and hot water output using the Thermostatic Control.

i **THERMOSTAT**

This appliance is designed to be controlled by the thermostat which regulates the rate fuel is burnt and the amount of heat produced to hot water. A trial and error approach will establish settings to suit personal preference.

- 5.10 The thermostat operates by controlling combustion air entering the boiler. The higher the thermostat setting the hotter the temperature of the water leaving the boiler. The lower the setting the lower the temperature of the water leaving the boiler.

! **NOTE IF THE THERMOSTAT IS SET TO MAXIMUM THE WATER LEAVING THE BOILER WILL BE APPROXIMATELY 85°C.**

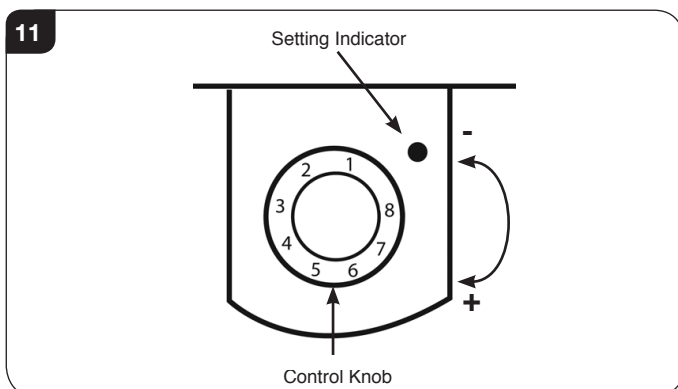

- 5.11 The exact setting of the thermostat and the Manual Air Controls may need slight adjustment by trial and error to suit requirements.

Operate the follow controls manually:

Secondary Air Control

Depending on the strength of the flue pull the **Secondary Air Control** should be adjusted so that air from the air inlets ignite unburnt smoke and flames are visible, but not so strong that flames reach the glass.

Primary Air Control

Small amounts of **Primary Air** can sometimes help to maintain a hot fuel bed and boost hot water output.

Airwash Control

Opening the Airwash Control will increase the visual flame.

Do not burn large amounts of fuel with the **Airwash Control** closed for long periods of time. This reduces the glass cleaning effect of the Airwash and causes tars and creosotes to build-up in the appliance and flue system.

- 5.12 Experience establishes settings to suit personal preference.

Over-firing

- 5.13 When in use, burning the appliance at a high temperature for a short period reduces tars and creosotes. **DO NOT OPERATE THE APPLIANCE WITH THE PRIMARY AIR CONTROL OPEN OR AIRWASH ON BOOST FOR LONG PERIODS OF TIME AS THIS COULD CAUSE OVER-FIRING AND MAY CAUSE PERMANENT DAMAGE.**

5b. Multi-fuel Stove

This section applies to all Multi-Fuel models when fitted with a Multi-fuel grate.

- Burning Solid Fuels, see 5.14.
- Burning Wood on a Multi-fuel Grate, see 5.26.

FOR CLARITY, THE FOLLOWING DIAGRAM DOES NOT INCLUDE ILLUSTRATIONS OF THE DOORS.

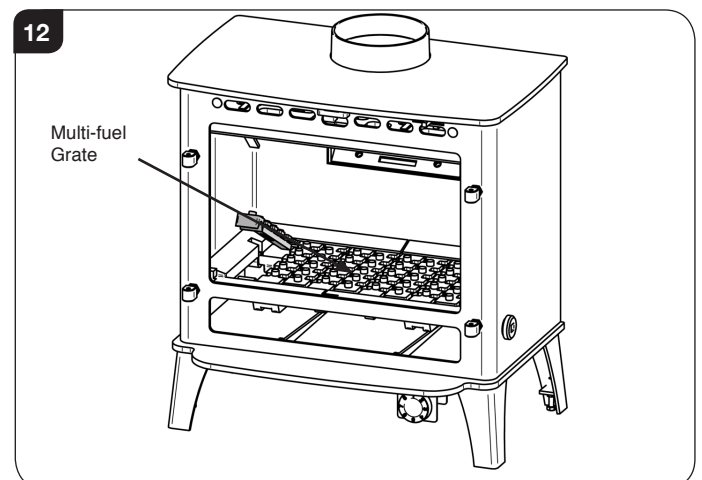

User Instructions

Wood can be burnt on the multi-fuel grate, but if wood is to be used constantly a Woodburning tray should be fitted, see Section 6.

Multi-fuel Stove - Solid Fuels

To burn smokeless fuels the cast iron multi-fuel kit supplied with the product must be fitted.

- 5.14 Allow the fire to become established before adding the solid fuel, see Section 4.
- 5.15 Open the **Primary Air Control** fully to establish a glowing bed before adding new fuel.
- 5.16 De-ash the grate before re-fuelling (see *User Instructions, Section 8*).
- 5.17 Add the correct amount of fuel, see Section 3.
- 5.18 **Close the doors immediately after refuelling.**

Burn new fuel at a high temperature for a few minutes before adjusting the **Primary Air Control** to the desired setting.

Refuel little and often for clean, efficient burning.

Manually operate the following air controls using a gloved hand or the tool provided.

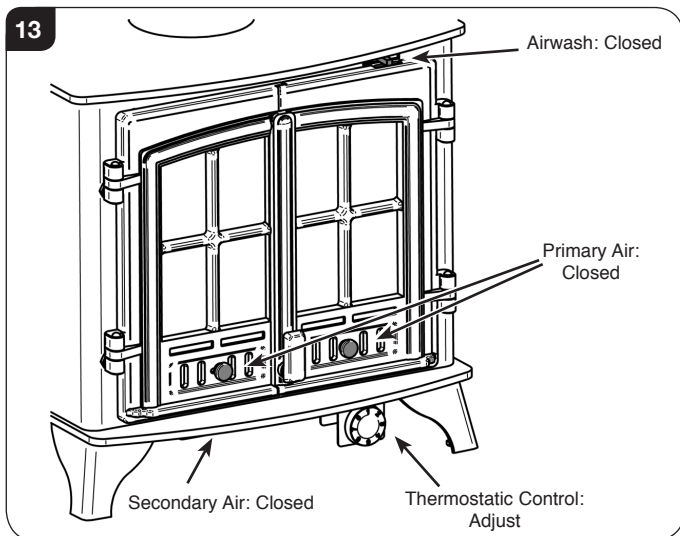

- 5.19 Close the **Primary, Airwash and Secondary Air Controls**.
- 5.20 Control the temperature and hot water output using the Thermostatic Control.



THERMOSTAT

This appliance is designed to be controlled by the thermostat which regulates the rate fuel is burnt and the amount of heat produced to hot water. A trial and error approach will establish settings to suit personal preference.

- 5.21 The thermostat operates by controlling combustion air entering the boiler. The higher the thermostat setting the hotter the temperature of the water leaving the boiler. The lower the setting the lower the temperature of the water leaving the boiler.



NOTE IF THE THERMOSTAT IS SET TO MAXIMUM THE WATER LEAVING THE BOILER WILL BE APPROXIMATELY 85°C.

14

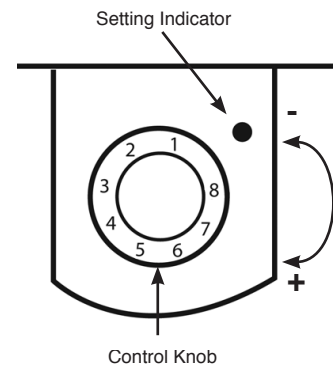

- 5.22 The exact setting of the thermostat and the manual Air Controls may need slight adjustment by trial and error to suit requirements.

Operate the follow controls manually:

Secondary Air Control

Always have the **Secondary Air Control** shut when burning solid fuel to ensure the maximum efficiency from the appliance.

Primary Air Control

When burning solid fuel more **Primary Air** will increase the heat output and burn the fuel more quickly.

Do not burn large amounts of fuel with the **Primary Air Control** on a low combustion setting for long periods of time. This causes tars and creosotes to build-up in the appliance and flue system.

Airwash Control

A small amount of **Airwash** can sometimes help to keep the glass clean but will reduce efficiency.

Experience establishes settings to suit personal preference.

Over-firing

When in use, burning the appliance at a high temperature for a short period reduces tars and creosotes. **DO NOT OPERATE THE APPLIANCE WITH THE PRIMARY AIR CONTROL OPEN OR AIRWASH ON BOOST FOR LONG PERIODS OF TIME AS THIS COULD CAUSE OVER-FIRING AND MAY CAUSE PERMANENT DAMAGE.**

- 5.23 **Only anthracite or smokeless fuels suitable for use in closed appliances must be burnt in this appliance.**

User Instructions

5.24 **Do not burn bituminous coal, 'petro-coke' or other petroleum based fuels as this invalidates the product guarantee.**

5.25 **Do not load fuel above the log guard and the base of the baffle at the back of the firebox, see Diagram 8.**

Multi-fuel Stove - Wood Burning

Wood can be burnt on the multi-fuel grate, but if wood is to be used constantly a Woodburning tray should be fitted, see Section 6.

5.26 Do not de-ash the grate. Wood burns best on a bed of ash (approx. 25mm (1") deep).

5.27 To burn wood on a Multi-fuel grate, follow the instructions in Section 5a from 5.2.

Shut Down

5.28 If there is still burning fuel in the firebox, Kensal do not recommend shutting down all of the air controls completely unless there is a chimney fire in progress (see section 10 for advice). Closing the controls during the burning process will cause poor combustion and could lead to a build up of gasses that could ignite dangerously.

5.29 Always have enough air entering the appliance to maintain some flame within the firebox.

5.30 If it is necessary to shut down the appliance then run on a high setting until all of the fuel has been burnt before closing the air controls.

6. Woodburning Tray

In order to burn wood continuously in a Multi-fuel appliance a Woodburning Tray must be fitted. For details on purchasing a Woodburning Kit for this appliance contact your retailer.

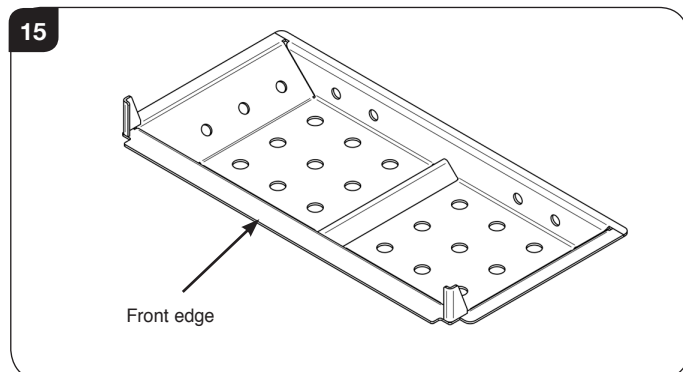

6.1 Remove the riddling mechanism from the appliance (see Pre-Installation, Section 5).

To fit the Wood Burning Tray:

6.2 Remove the log guard and ashpan.

6.3 Hold the tray flat with the front edge pointing forwards, tilt diagonally and insert through the front of the appliance, see Diagram 15.

Ensure that the lower log guard support is inserted first to achieve the correct angle.

FOR CLARITY, THE FOLLOWING DIAGRAM DOES NOT INCLUDE ILLUSTRATIONS OF THE DOORS.

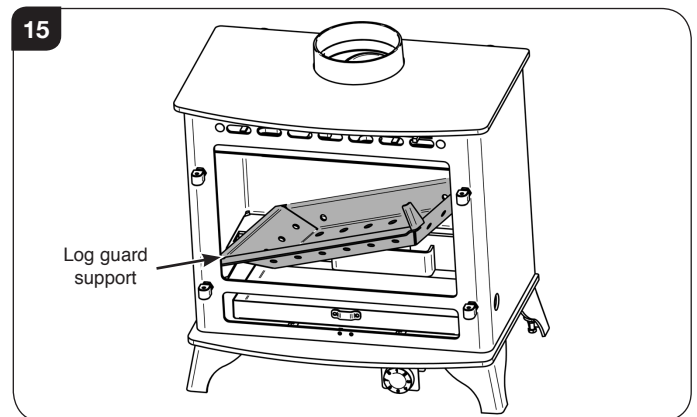

6.4 Place tray flat on the fixings on the firebed, see Diagram 16.

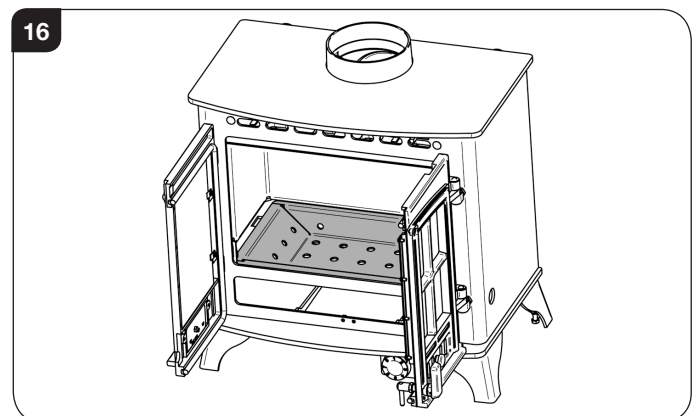

6.5 Fit the plug supplied into the hole where the riddling mechanism is normally located and secure with bolt and clamp (also supplied), see Diagram 17.

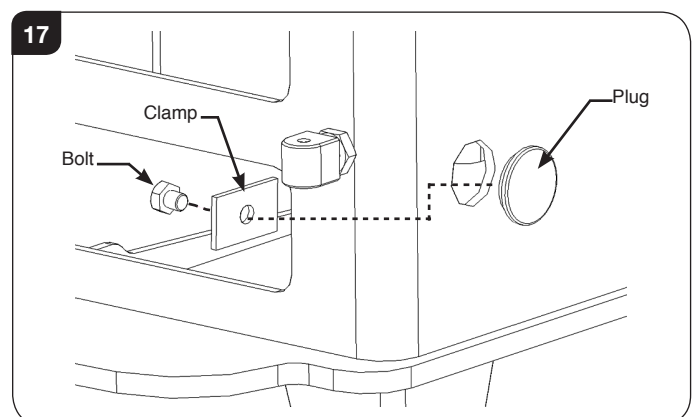

6.6 Replace the log guard and the ashpan.

Care & Maintenance

7. Extended Burning

- 7.1 It is possible to get the appliance to burn for extended periods of time. In order to do this:
- De-ash prior to final refuelling.
 - Burn new fuel at a high temperature for a few minutes before adjusting the **Primary Air Control**.
 - Set air controls to low combustion settings. This will gradually blacken the glass but it will clear when operated at a high temperature for a short period.

8. Ash Removal

Do not allow ash to build up as it may cause damage and adversely effect the performance of the appliance. Warning: Ash can remain hot long after appliance has been in use.

- 8.1 **Burning Wood with a Woodburning tray**
- Open Doors.
 - Leave a layer of ash to start the new fire on. Wood burns best on a bed of ash (approx. 25mm (1") deep).
 - Remove excess ash from the Woodburning tray with a small shovel and place into a Ash Caddy (Part No. 4227) or other suitable container.
 - Rake the remaining ash evenly over the firebed.

Warning: Ash can remain hot long after appliance has been in use.

- Using gloves, carefully remove ashpan using tool supplied, see Diagram 22. Ensure the tool is fully engaged before operation. Practise this technique before hand with a cold ashpan.
- Place the ash into an Ash Caddy (Part No. 4227) or other suitable container.

Do not place hot ash in any container made from plastic or any other combustible material.

- De-ash at least once a week.

8.2 **All fuels: (When fitted with a Multi-fuel grate)**

Burning Solid Fuels:

- De-ash the appliance before filling with new fuel. Do not allow ash to build up on the underside of the grate as this can cause premature failure.

Burning Wood:

- Leave a layer of ash on top of the riddling bars to start the new fire on. Wood burns best on a bed of ash (approx. 25mm (1") deep).

All Fuels:

- Insert the Riddling Tool into the socket, see Diagram 18.

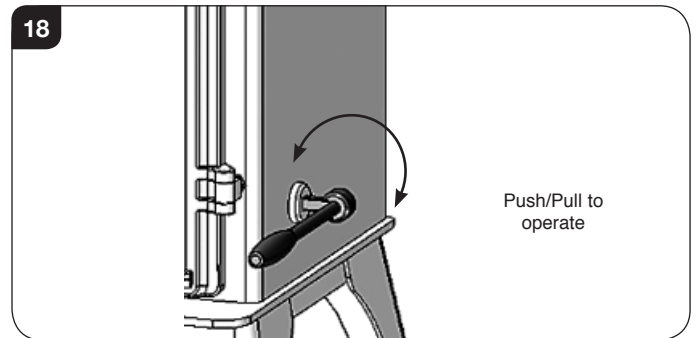

- Rotate the Riddling Tool backward and forward 3 or 4 times to remove the ash. Do not force the handle beyond its natural stop point. The ash will fall into the ashpan.

8.3 Open the door.

Warning: Ash can remain hot long after appliance has been in use.

Using gloves, carefully remove ashpan using tool supplied, see Diagram 19. Ensure the tool is fully engaged before operation. Practise this technique before hand with a cold ashpan.

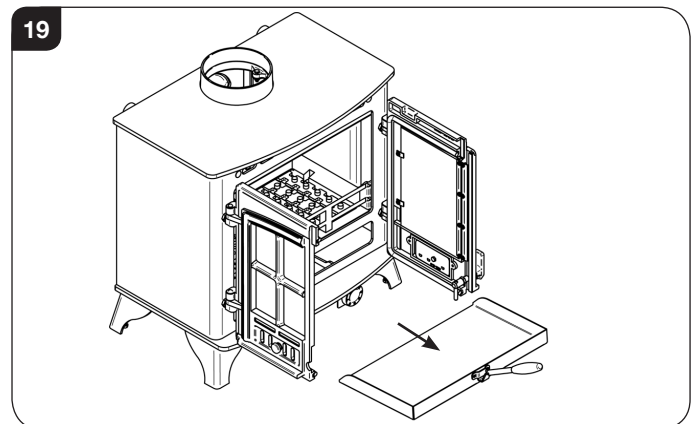

- 8.4 Place the ash into an Ash Caddy (Part No. 4227) or other suitable container.
- 8.5 Check and remove ash as often as required when burning solid fuel.
- 8.6 De- ash at least once a week.
- 8.7 Do not place hot ash in a container made from plastic or any other combustible material.

Care & Maintenance

9. Over-Firing

- 9.1 Do not over-fill with fuel or run at high temperatures for long periods or over-firing can occur.
DO NOT OPERATE THE APPLIANCE WITH THE PRIMARY AIR CONTROL OPEN OR AIRWASH ON BOOST FOR LONG PERIODS OF TIME AS THIS COULD CAUSE OVER-FIRING AND MAY CAUSE PERMANENT DAMAGE.
- 9.2 **Over-firing can cause permanent damage to the appliance and invalid the product warranty.**

10. Chimney Fire

- 10.1 **If a chimney fire occurs:**
- Shut all air controls immediately.
 - Evacuate the building.
 - Call the fire brigade.
 - Do not re-enter the building until it is confirmed safe.
- 10.2 **Do not use the appliance after a chimney fire until:**
- a) **It has been inspected by a registered installer*, confirming the appliance is safe to use.**
- b) The chimney system has been inspected and swept by a chimney sweep, confirming the system is structurally sound and free from obstruction*.
- c) **It is repaired as required before re-use.** Use only genuine Kensal replacement parts to keep your appliance in safe, efficient working order.

11. General Cleaning

- 11.1 Clean and inspect the appliance regularly, especially in periods of heavy use. Regular cleaning and maintenance will help give many years of safe use.
- 11.2 **Allow appliance to cool thoroughly to avoid risk of burns.**
- 11.3 Clean regularly, according to level of use.
- Remove the ash completely.
 (See *User Instructions, Section 8*).
- 11.4 Check the internal components for damage and for obvious build up of soot, ash or debris above the flue baffle(s) (these can be found in the upper part of the firebox). Use a torch if necessary.
- 11.5 If there are any signs of a build up of debris above the flue baffle(s) either:
- Arrange for the chimney to be swept (see *Care & Maintenance Instructions, Section 13*).
 - Remove the baffles and clear the debris (see *Pre-Installation Instructions, Section 3*).

- Remove the cleaning plate from the back of the appliance and clear the debris.
 (see *Pre-Installation Instructions, Section 4*)

- 11.6 Clean matt black appliances using Colloidal black or Grate Polish.
- 11.7 To refresh painted finishes a touch up spray is available. Contact your Kensal retailer quoting the serial number found on the appliance date badge.

Do not use aerosol sprays near an operating appliance.

Do not use abrasive cleaner or cleaning pads.

Check that the door shuts properly and creates an effective seal. Leaking door seals prevent the appliance working properly.

12. Cleaning Glass

- 12.1 Keep the glass clean with correct use of the Airwash system and good quality fuel. Use the boost setting to clear any build up.
- 12.2 Sometimes additional cleaning may be required. Before undertaking this operation allow appliance to cool fully. Do not clean hot glass.
- 12.3 **On appliances with printed glass do not use cleaning agents that have a high alkaline or acidic content, for example Stovax Gel Cleaner, these are aggressive cleaning agents designed to be used with heavily stained clear glass. On printed glass surfaces, use Stovax Glass Cleaner (Stovax No.4103) which is better formulated for this application.**
- 12.4 Before applying a cleaning agent remove any dust and loose soot with a damp cloth.
- 12.5 Use an appropriate glass cleaner. Apply the cleaning fluid to a cloth before rubbing onto the glass. Apply carefully and do not apply excessively. Try to prevent any run off which could soak into the rope seals around the edge of the glass.
 Soot can also contain acidic particles that can cause corrosive damage to printed glass.
- 12.6 Remove dirt with a moist cloth and buff dry.
- 12.7 **Some types of wood and solid fuel can cause a white residue to form on the glass. If this occurs it should be cleaned off at least once a week during periods of heavy usage. If the liquid cleaning agents recommended do not remove this residue use a dry cleaning pad which will help remove these white marks.**
- 12.8 Before relighting the appliance ensure the glass is fully dried. If the rope seal has absorbed excess cleaning agent it is advisable to replace the rope as soon as possible to preserve the printed finish of the glass.



*Registered on the Competent Persons Scheme (GB only) see page 39/ INFO (Republic of Ireland).

Care & Maintenance

13. Chimney Sweeping

- 13.1 To maintain safe and efficient use of the appliance, the chimney/flue must be inspected and swept at least once a year by a qualified chimney sweep*.

In order to gain access to the chimney/ flue it may be necessary to remove the cleaning plate and Secondary Air Chamber, (see *Pre-Installation Section 4*).

If the appliance is used continuously throughout the year, or it is used to burn wood, more frequent sweeping is recommended.

The best time to have the chimney swept is at the start of the heating season.

- 13.2 The chimney, any connecting flue pipe and the appliance flue ways, if incorporated, must be regularly cleaned.
- 13.3 Ensure adequate access for cleaning where it is not possible to sweep through the chimney.
- 13.4 If the chimney is believed to have previously served an open fire it must be swept a second time within a month of regular use after installation.

14. Care Of Stove

Stovax has a range of cleaning and maintenance products and accessories to keep your appliance in good working order. Your Kensal retailer can advise you on suitable items for your appliance and provide genuine spare parts such as replacement glass, door sealing rope and firebricks. View the extensive range at www.stovax.com by clicking on *Accessories*. In addition, an annual service by a competent engineer is recommended to keep your appliance in the best possible condition.



*Registered on the Competent Persons Scheme (GB only) see page 39/ INFO (Republic of Ireland).

15. Seasonal Use

- 15.1 Clean and service the appliance if not used during the warmer months, as detailed in the *Maintenance and Servicing* section.
- 15.2 Set the air controls to 50% to keep the appliance ventilated and stop the build-up of any moisture inside.
- 15.3 Before re-lighting the appliance:
- Remove the baffles.
 - Clear any debris that may have accumulated.
 - Check the flue is clear of any blockages.
- 15.4 If this appliance is unused for lengthy periods of time it should be periodically checked to ensure that condensation is not building up within the appliance.

NOTE – THIS CONDENSATION IS NORMAL AND DOES NOT INDICATE A FAULTY OR LEAKING APPLIANCE.

- 15.5 If the appliance is going to be unused for very long periods of time it is recommended to drain the system.

16. Optional Extras

Woodburning Tray

- 16.1 In order to burn wood continuously in a Multi-fuel appliance a Woodburning Tray must be fitted. For details on purchasing a Woodburning Kit for this appliance contact your retailer.

17. Radiator Troubleshooting

17.1 All or some of the radiators do not get hot

Burning wood	Wood is burning too slowly	Open up the airwash to make a hotter fire
		If fitted set the thermostat to a higher setting
		Burn dryer wood
		Burn better quality wood
		Reduce ashbed to 1" thick
Burning Solid Mineral fuels	Fuel is burning too slowly	Open up the primary air to make a hotter fire. If fitted, set the thermostat to a higher setting
		The fire needs riddling to remove ash. De-ash the fire
		Empty the ash pan.
All Fuels	Appliance is not producing much heat.	Not enough fuel.
	System faults	Bleed the radiators to ensure there are no air locks.
		Incorrect system design seek professional assistance
		Too many radiators in the system exceeding the appliances capabilities.

17.2 In the unlikely event of a problem that cannot be solved by these tips contact your installer or retailer for help.

Troubleshooting

Troubleshooting

	Symptom	Cause	Solution
OPERATION	Difficulty starting the fire and keeping it burning well	Low flue draught	Consult your installer
		Wet wood (over 20% moisture)	Use dry seasoned wood (less than 20% moisture content)
	Poor burning control	High flue draught	Consult your installer
	Short burn times	Wet wood (over 20% moisture) Insufficient amount of fuel - Refer to the table in section 3	Use dry seasoned wood (less than 20% moisture content)
	Excessive heat output (Over firing)	High flue draught	Consult your installer
		Air control left fully open	Close air control to reduce output
	Low heat output to room	Low flue draught	Consult your installer for advice on suitable flue system
		Wet wood (over 20% moisture)	Use dry seasoned wood (less than 20% moisture content)
	Low heat output to water	Insufficient fuel	See User Instructions Section 3
		Air controls set incorrectly	See User Instructions Section 5
Heating System fault		Consult your installer	
Excessive fuel consumption	High flue draught	Consult your installer for advice on suitable flue system	
	Over dry wood	Do not use constructional timber or pallet wood	
SMOKE EMISSIONS	Smoke and small flames	Wet wood (over 20% moisture)	Use dry seasoned wood (less than 20% moisture content)
	Intermittent smoke spillage into room when appliance door is opened	Low flue draught	Consult your installer for advice on suitable flue system
		Incorrect additional ventilation air in to building	Consult your installer
	Continuous smoke spillage into room when appliance in use	Blocked flue	Open all doors and windows to ventilate the room. Allow the fire to burn out. Check flue for blockage. Do not re-use until cause of spillage is identified. Consult your installer for advice
Blue/grey smoke from chimney	Wet wood (over 20% moisture)	Use dry seasoned wood (less than 20% moisture content)	
ADVERSE WEATHER	Windy days, intermittent smoke spillage into room when appliance door is opened	Down draught in flue caused by air turbulence caused by nearby buildings or trees	Weather conditions combined with the flue terminal position can have an effect on the appliance performance. Consult your installer
	Calm days, intermittent smoke spillage into room when appliance door is opened	Over size flue giving poor flue draught	Weather conditions combined with the flue terminal position can have an effect on the appliance performance. Consult your installer
	Damp/Rainy days lighting and burning problems	Flue temperature low / rain water inside flue	Use good quality wood to start and maintain the fire, consult your installer to fit a rain cowl
	Wind noise from the air control	High flue draught	Consult your installer for advice on suitable flue system

Troubleshooting

	Symptom	Cause	Solution
THE APPLIANCE	Rapid creosote build-up in the chimney	Wet wood (over 20% moisture)	Use dry seasoned wood (less than 20% moisture content). Operate at a high temperature for short periods each time the appliance is used to avoid large build-ups of tars and creosotes
	Tar coming from flue joints	Appliance operated at continuous low temperatures	Operate at a high temperature for short periods each time the appliance is used to avoid large build-ups of tars and creosotes. See user instructions for correct use of air control
		Using poor quality wood	Use dry seasoned wood (less than 20% moisture content)
	Strong pungent smell after the appliance is lit	Appliance operated at continuous low output	Operate at high output for short periods. See user instructions for correct use of air control
		Using poor quality wood	Use dry seasoned wood (less than 20% moisture content)
	Wind noise from the air control	High flue draught	Consult your installer for advice on suitable flue system
	Dirty glass	Wet wood (over 20% moisture)	Use dry seasoned wood (less than 20% moisture content)
	Glass blackening	Using poor quality wood	Use dry seasoned wood (less than 20% moisture content)
		Low flue draught	Consult your installer for advice on suitable flue system
		Incorrect use of air control	See user instructions for correct use of air control
Appliance operated at continuous low temperatures		Operate at high output for short periods. See user instructions for correct use of air control	

FLUES	<p>The flue system has two main functions:</p> <ul style="list-style-type: none"> - To safely remove the smoke, fumes and combustion gases from the building. - To provide a sufficient amount of flue draught (suction) in the appliance to ensure the fire keeps burning.
	<p>The flue draught is caused by rising hot gases when the appliance is lit.</p>
	<p>Tar and creosote are a major cause of chimney fires. If the appliance experiences problems with tar build up consult a chimney sweep before continued use of the appliance.</p>
	<p>For advise on the correction of persistent flue problems consult a qualified heating engineer before continuing to use the appliance.</p>

Installation Checklist

Please Note

This section is intended to give an overview of the product performance and essential information required for installing the appliance. It is intended for qualified engineers who are already familiar with Kensal products. For full details and expanded information please see the Technical Appendix at the back of this manual.

1. Kensal Dimensions

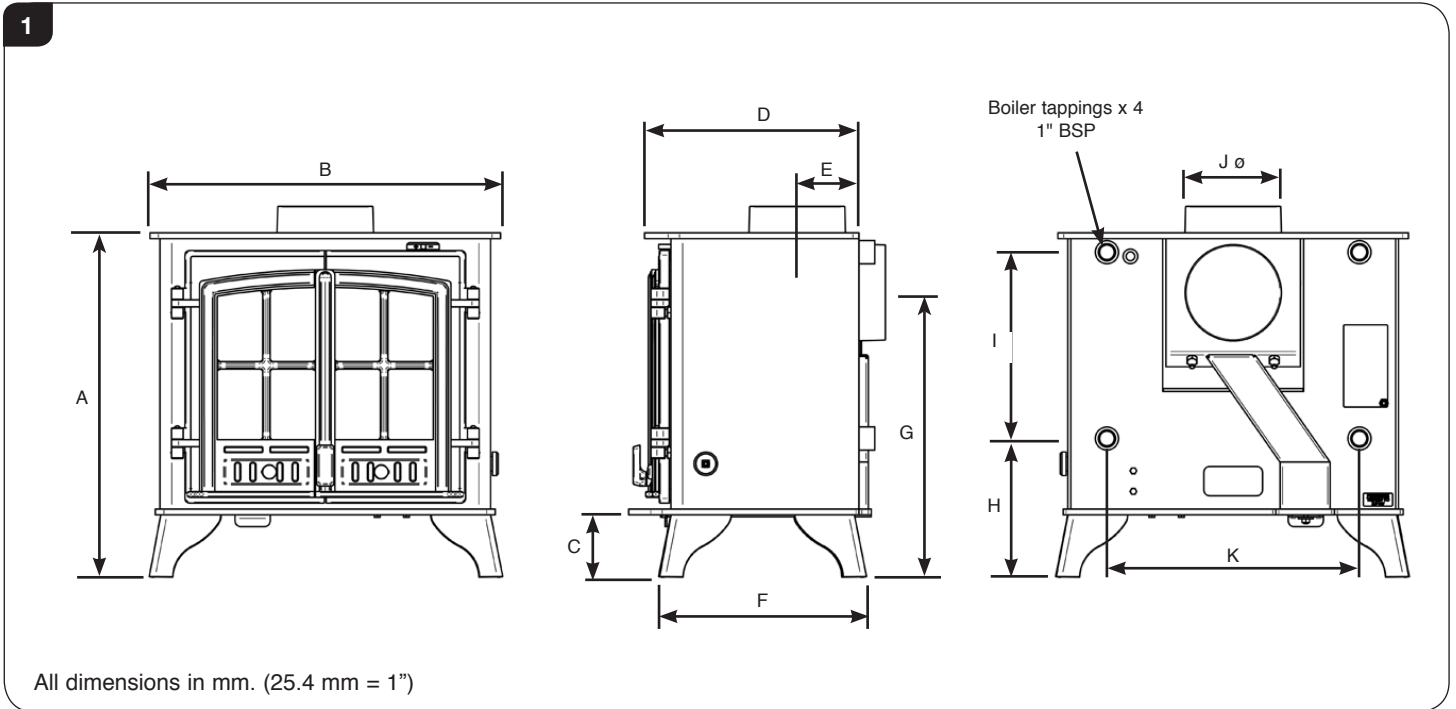

Description	A	B	C	D	E	F	G	H	I	J (dia)	K
Kensal 40	587	597	106	365	105	405	484	236	317	153	430
Kensal 60	679	717	159	405	117	454	578	289	357	153	550

i In the U.K. Additional information covering the installation of the appliance may be found in the following British Standards: BS EN 15287, BS6999, BS8303.

Installation Checklist

2. Essential Information

GENERAL	Model:				
	Kensal 40				
	Kensal 60				
	Nominal Heat Output to Room	Wood	kW	6.0	6.4
		Solid Fuel	kW	6.0	6.4
	Nominal Heat Output to Water	Wood	kW	7.0	11.0
		Solid Fuel	kW	8.0	11.0
	Efficiency	Wood	%	70	69
		Solid Fuel	%	72	72
	CO @ 13% O ₂	Wood	%	0.29	0.55
Solid Fuel		%	0.39	0.25	
Weight	Wood	Kg	-	162	
	Solid Fuel		135	176	
Recommended Fuels	Wood	Seasoned Wood (less than 20% moisture content)			
	Solid Fuel	Briquette smokeless fuel suitable for closed appliances (Ancit-Phuracite-Taybrite-Homefire Ovals)			

As tested to the requirements of EN 13240 for intermittent operation

FLUES	Flue/Chimney Size	Without flue liner Round (Diameter)	mm	153	153
			inch	6	6
		Without flue liner system (Square)	mm	135	135
			inch	5 ¹ / ₂	5 ¹ / ₂
		With Liner of Factory made system (diameter) installed in accordance with manufacturers instructions	mm	153	153
			inch	6	6
	Flue/Chimney minimum height**	All products	m	4.5	4.5
			feet	15	15
	Flue Draught	Min	mm Wg	1.0	1.0
		Nominal		1.25	1.25
		Max		2.0	2.0
	Flue Gas Mass Flow	Wood	g/s	12.1	15.3
		Solid Fuel	g/s	10.5	14.8
	Flue Gas Temperature at Spigot/Socket	Wood	°C	377	400
Solid Fuel		°C	377	400	
Flue Outlet Size (Top or Rear Option)	All	mm	153	153	
		inch	6	6	

European Min Spec for Chimney Flue - T400 N2 D 3 G50

VENTILATION	A) Traditionally Built Homes		B) Modern Construction Homes		
	• Where leakage is greater than 5m ³ /hour/m ² .		• Where leakage is less than 5m ³ /hour/m ² .		
	• Ventilation normally required = 550mm ² per kW output over 5kW		• Ventilation normally required = 550mm ² per kW		
	A	Additional Ventilation	mm ²	4950	6600
			cm ²	49.5	66
			in ²	8	10.6
	B	Additional Ventilation	mm ²	7700	9350
cm ²			77	93.5	
in ²			12.4	15.1	

For full technical details on ventilation see Technical Appendix on Page 38

Installation Checklist

3. Boiler Output Charts

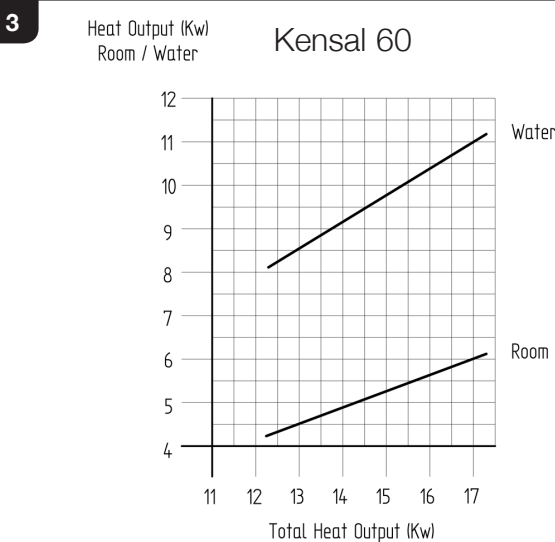
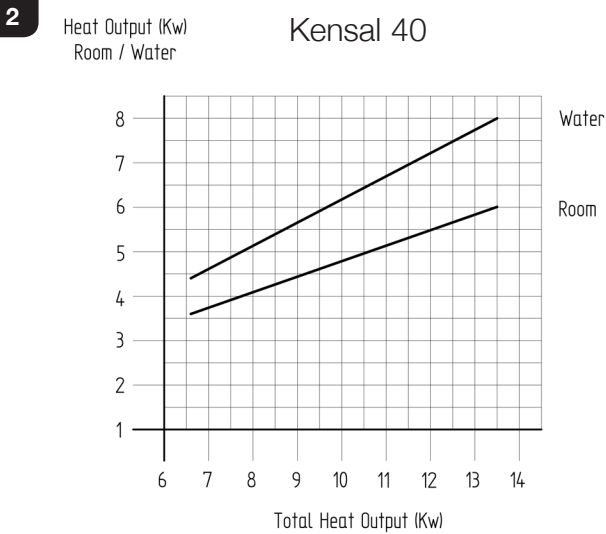

4. Minimum Dimensions - Hearth

- 4.1 The appliance must stand on a non-combustible constructional hearth which is at least 125mm thick with the minimum dimensions as shown in Diagram 4.

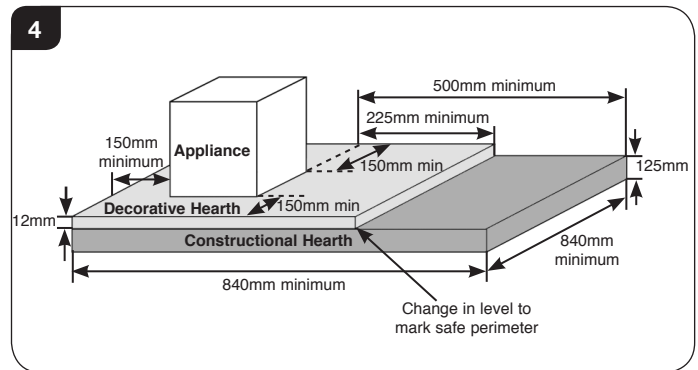

- 4.2 If this appliance is installed in an elevated setting it is recommended to increase the 225mm hearth depth to safely contain any falling logs or embers. The higher the appliance is installed the deeper the hearth should be to avoid scorched floor coverings.

5. Clearances

IMPORTANT: INSTALLATION MUST COMPLY WITH CURRENT BUILDING REGULATIONS

ENSURE THAT SUFFICIENT CLEARANCES ARE PROVIDED BETWEEN THE FLUE PIPE AND ANY COMBUSTIBLE MATERIALS IN THE FIREPLACE IN ACCORDANCE WITH THE RULES IN FORCE.†

- 5.1 When installing a Kensal boiler it is important to observe the following clearances to both **combustible** and **non-combustible** materials. Also ensure that a clearance of 1 meter is maintained in front of the appliance when operating.

Fireplace: Minimum Clearances Above & to the Sides

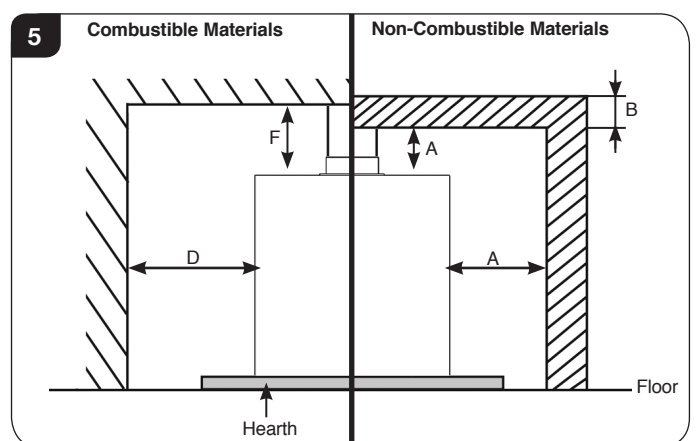

i † England and Wales – Document J / Scotland - Part F/Document J (Republic of Ireland only)

Installation Checklist

Fireplace: Minimum Clearances to the Rear

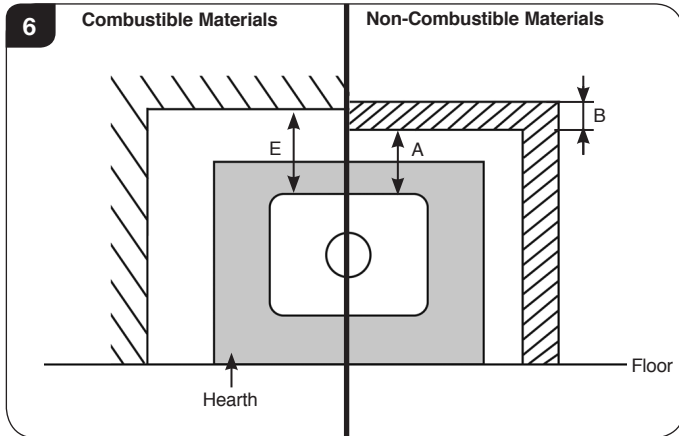

Non-Combustible Materials

- 5.2 All appliances will require some clearance between them and any non-combustible materials to allow for either:
- Installation, servicing or accessing controls.
 - Convection in order for the appliance to function properly.

Minimum clearances for installation/servicing/convection is:

Rear - 25mm	Sides 50mm	Top 100mm
-------------	------------	-----------

NOTE: If the non-combustible surface is less than 200mm thick additional clearances may be required. This requirement ensures that the non-combustible material does not transmit excessive heat through the wall onto combustible material which might be placed against it.

See Diagrams 5 & 6 (Fireplaces) & Diagram 7 (Freestanding) and table below.

Distance to Non-combustible Materials		
Distance of Appliance to Wall (A)	Minimum Thickness of wall (B)	Minimum Height of Wall (C)
0mm - 50mm	200mm	Height of appliance + 300mm OR 1200mm from the hearth (take largest dimension)
51mm - 300mm	75mm	
300mm+	No requirement	No requirement

Freestanding Installation

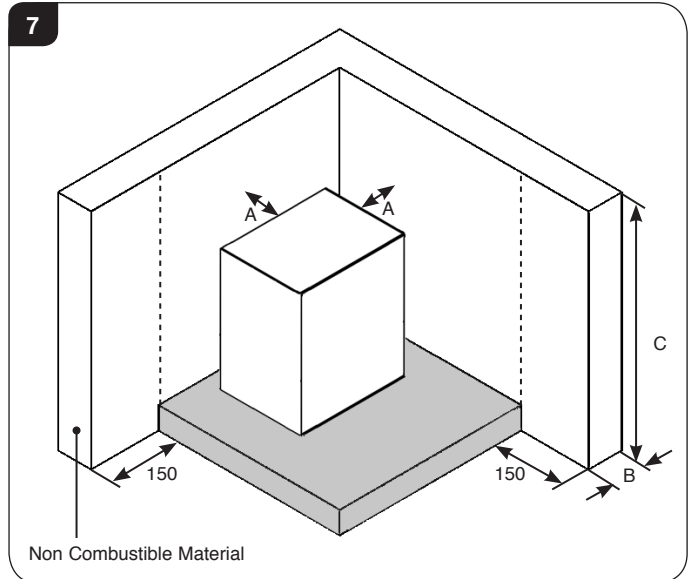

Combustible Materials

- 5.3 It is essential for safety to ensure the following clearances to combustible materials are maintained.

See Diagrams 5 & 6 and table below.

Distance to Combustible Materials			
Model	D (side)	E (Rear)	F (Above)
Kensal 40	150	250	N/A
Kensal 60	150	250	N/A

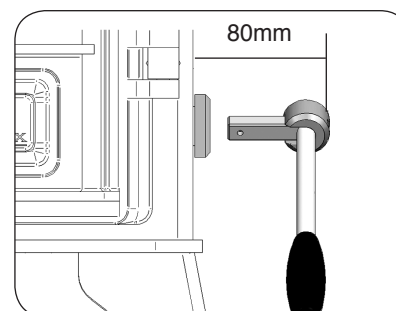

Note: When installing a Multi-fuel appliance a minimum gap of 80mm must be left on the Right Hand Side so that the riddling tool can be comfortably engaged in the socket.

6. Optional Extras

Woodburning Tray

- 6.1 In order to burn wood continuously in a Multi-fuel appliance a Woodburning Tray must be fitted. For details on purchasing a Woodburning Kit for this appliance contact your retailer.

Pre-Installation Instructions

1. General

- 1.1 To make the installation of the appliance easier it is best to remove the internal components before fitting into the builders opening/studwork.

PACKING LIST

All Models:

- User & Installation Instructions
- Warranty card
- Pair leather gloves
- Ashpan
- Ashpan tool
- Riddling tool (Multi-fuel only)
- Cleaning plate
- Flue collar
- Thermostat
- Thermic seal

STANDARD FEATURES

All Models:

- Primary air (under grate air for full multi-fuel use)
- Airwash (for wood burning / clean glass)
- Adjustable secondary air control (to ensure complete burning of flue gases)
- Top or rear flue exit option

Multi Fuel:

- Riddling grate system for clean de-ashing

- 1.2 For the best results removing the following components as set out below.

2. Removal of the Log Guard

- 2.1 To remove the Log guard:
- Lift Log Guard clear of the supporting brackets.
 - Rotate to clear the sides of the door opening.

Do not use appliance without the log guard in position.

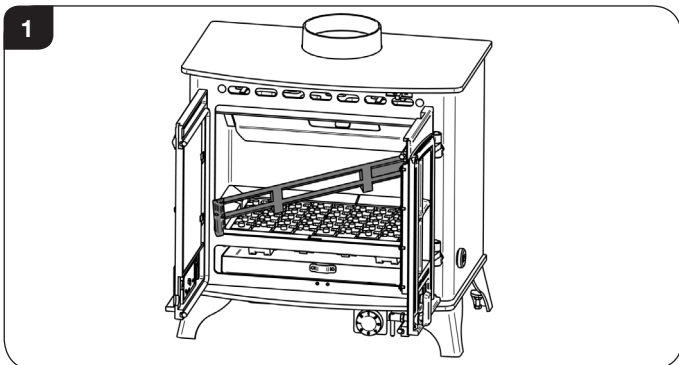

3. Removal of the Baffle

No tools are required.

- 3.1 To maintain efficient combustion the appliance is fitted with a baffle system that allows for secondary combustion, see Diagram 2.

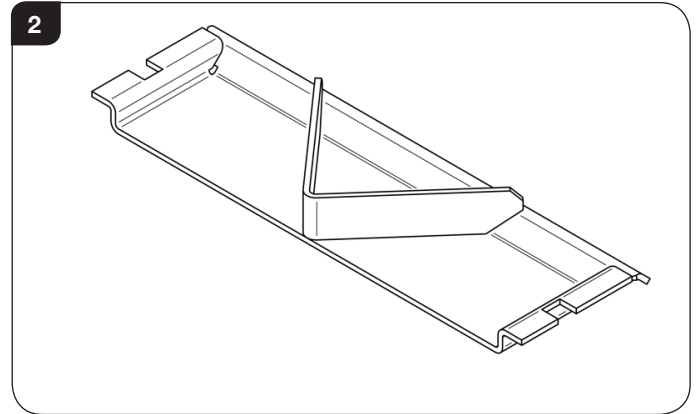

Allow the appliance to cool fully before removing the baffle system.

- 3.2 First remove the log guard from the appliance to give access to the firebox.
- 3.3 Use both hands to lift the baffle vertically to clear the side supports and the Secondary Air Chamber, see Diagram 3. Always wear gloves when handling appliance parts.

FOR CLARITY, THE FOLLOWING DIAGRAMS DO NOT INCLUDE ILLUSTRATIONS OF THE DOORS.

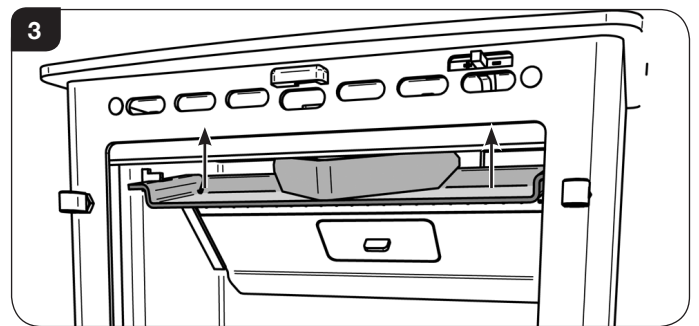

- 3.4 Using both hands rotate the baffle to remove from the firebox through the door opening.

Pre-Installation Instructions

3.5 Replace in reverse order.

Note: When installed correctly the front of the baffle fits over the supports on the inside of the firebox and the back fits over the Secondary Air Chamber, see Diagram 4.

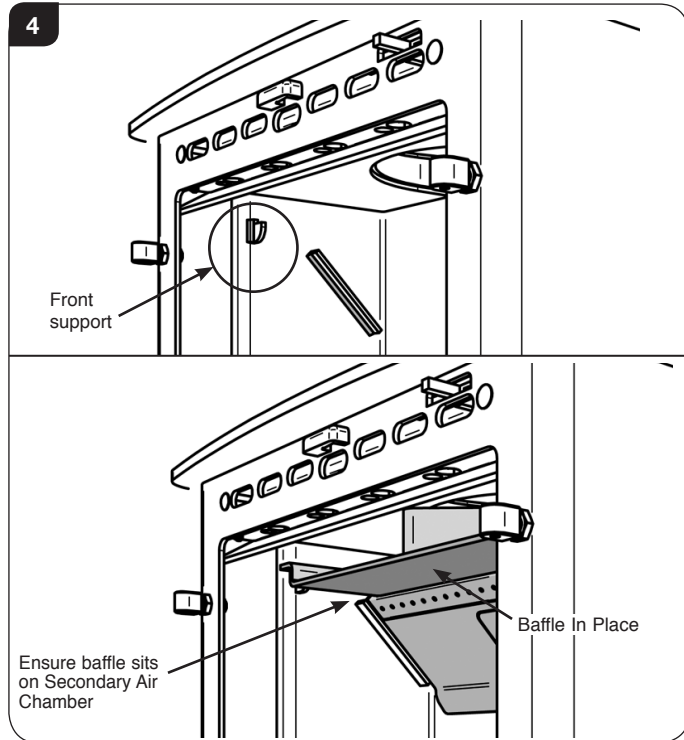

3.6 Remove and clean the baffle system to ensure the flue ways are clear of soot and debris and to ensure the safe, efficient operation of the appliance. The frequency of cleaning will depend on the appliance operating conditions.

3.7 The baffle system is designed to give safe and efficient operation of the appliance. **Replace any damaged baffle immediately.**

3.8 **Do not modify the baffle system.**

4. Removal of the Secondary Air Chamber

Tools required - 8mm Hex Key.

The Secondary Air Chamber can be removed to ease installation and will need to be removed in order to sweep the chimney.

To remove the Secondary Air Chamber:

4.1 Remove the baffle, see Section 3.

4.2 Remove the cleaning plate by lifting and rotating through the cleaning hatch in the Secondary Air Chamber, see Diagram 5.

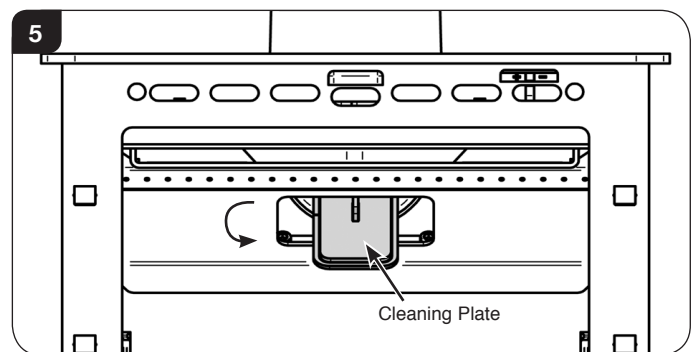

4.3 Use an 8mm Hex key to remove the 2 bolts, see Diagram 6.

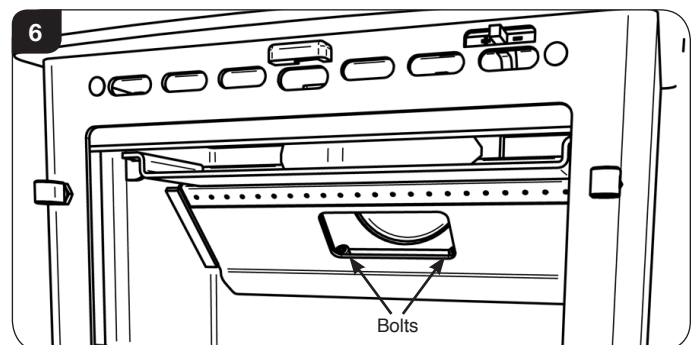

4.4 Use both hands to lift the Secondary Air Chamber vertically and rotate forward to disengage from the side supports.

4.5 Replace in reverse order, ensuring that the Air Chamber fits over the supports on the inside of the firebox, see Diagram 7.

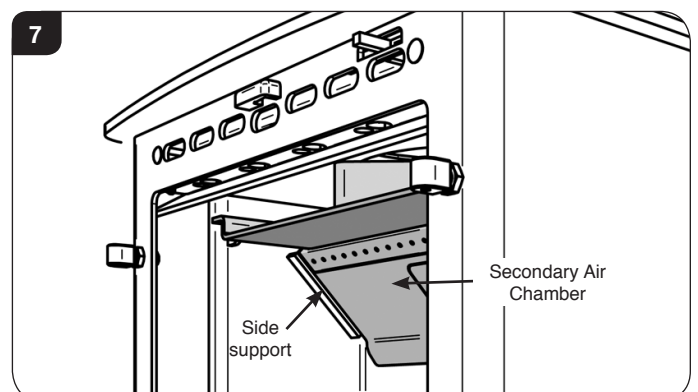

Pre-Installation Instructions

5. Removal of the Riddling Mechanism

The riddling mechanism can be removed for cleaning to maintain good working condition.

To remove the riddling mechanism:

- 5.1 Remove the baffle, see Section 3.
- 5.2 Remove the log guard to enable access, see Section 2.
- 5.3 Remove the ashpan.
- 5.4 Remove the riddling bars, see Diagram 8.

FOR CLARITY, THE FOLLOWING DIAGRAMS DO NOT INCLUDE ILLUSTRATIONS OF THE DOORS.

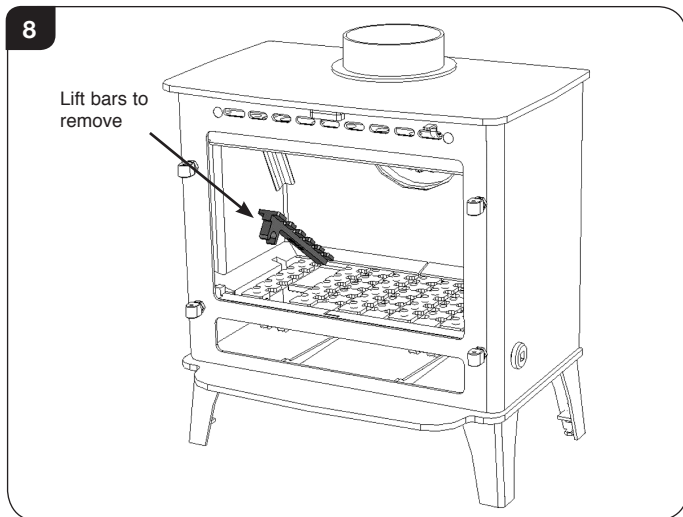

- 5.5 Remove Rear Bar, see Diagram 9.

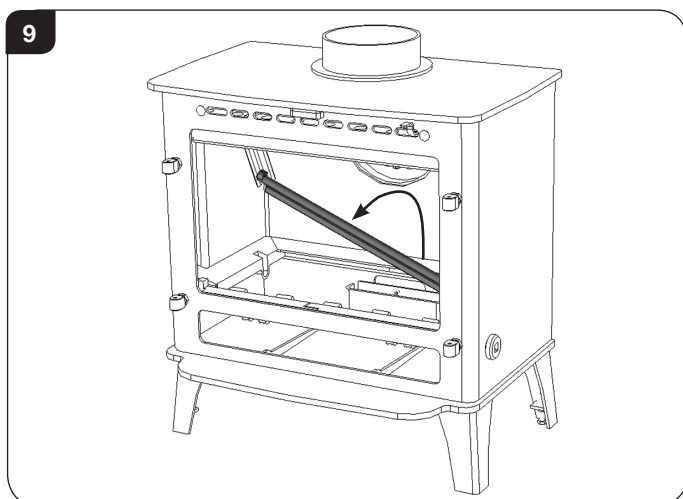

To remove the Riddling Boss:

- 5.6 Use the 5mm hex key as shown in Diagram 10.

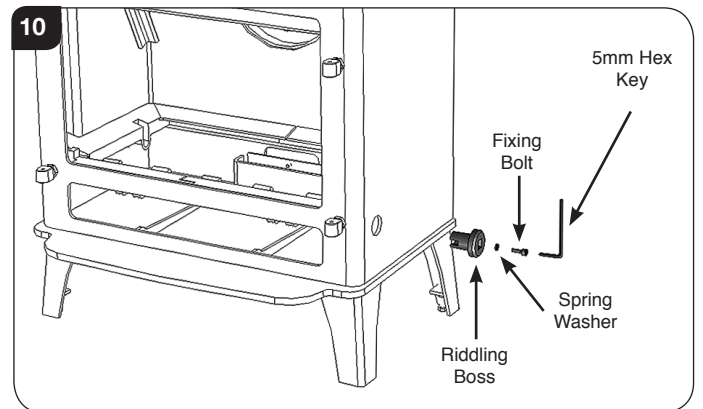

- 5.7 Unscrew the boss.
- 5.8 Remove Riddling Cam Bar, see Diagram 11.

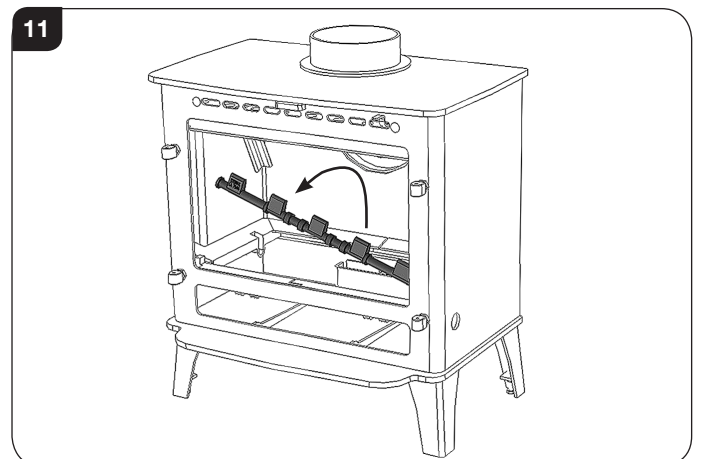

To remove Multi-fuel frames:

- 5.9 Lift frames from the front.
- 5.10 Remove right hand side first through the front of the appliance.
- 5.11 Repeat for the left hand side.

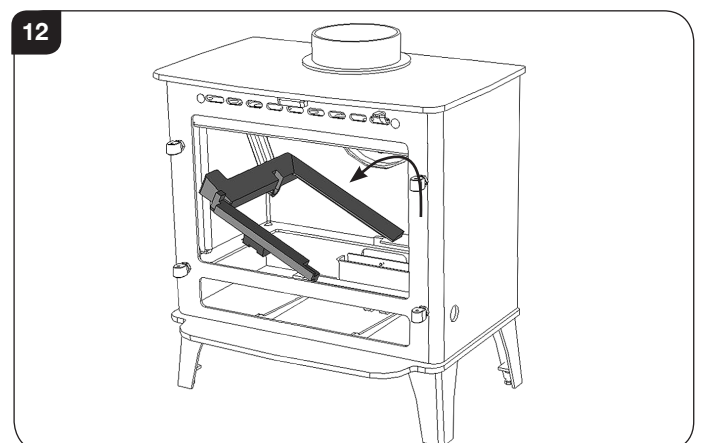

- 5.12 Replace in reverse order.

Installation Instructions

1. Installing the Appliance

Each installation is unique to the property so it is not possible to give details to suit every setting. The installation must comply with Building Regulations† and be made using "best practice" construction methods‡.

Many fireplace openings have a supporting lintel. Do not remove without supporting the remaining structure of the building. **Do not support the structure or the flue system with the appliance.**

1.1 **Take care when installing the appliance. Careless handling and use of tools can damage the finish and/or area.**

i This appliance is designed to be controlled by a thermostat which regulates the rate fuel is burnt and the amount of heat produced to hot water.

Note: It is recommended that the thermostat is fitted before the appliance is installed. For installation details refer to the instructions (PM747) supplied with the thermostat kit.

1.2 Choose top or rear flue exit, see Diagram 1.

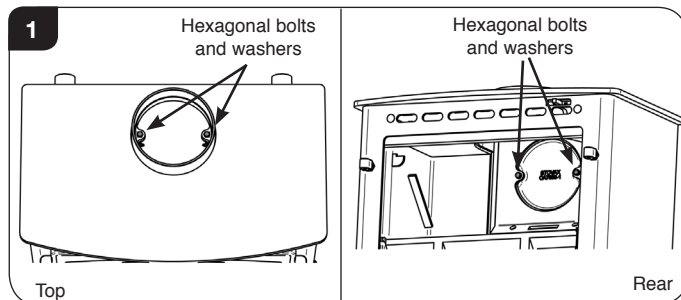

- Fit flue collar and blanking plate to suit.
- Attach flue collar to top or rear with hexagonal bolts, see Diagram 1.
- Seal collar with fire cement.
- Secure blanking plate with hexagonal bolts, see Diagram 2.

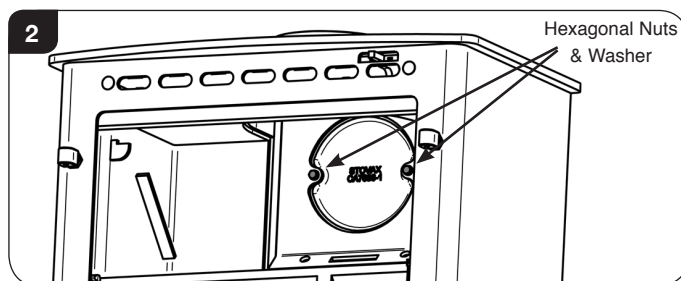

Ensure that the heating system, including pipework, has been carefully planned before installation.

1.3 **Top flue pipe installation**

- Lift appliance into position. Take care not to damage the hearth finish.
- Level the appliance. Connect appliance to the chimney using flue pipe.

- Secure with self tapping screw.
- Seal the connecting joints with fire cement.

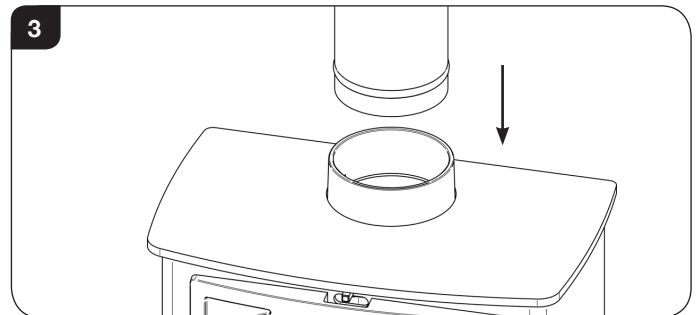

The flue must be installed in accordance with manufacturers instructions.

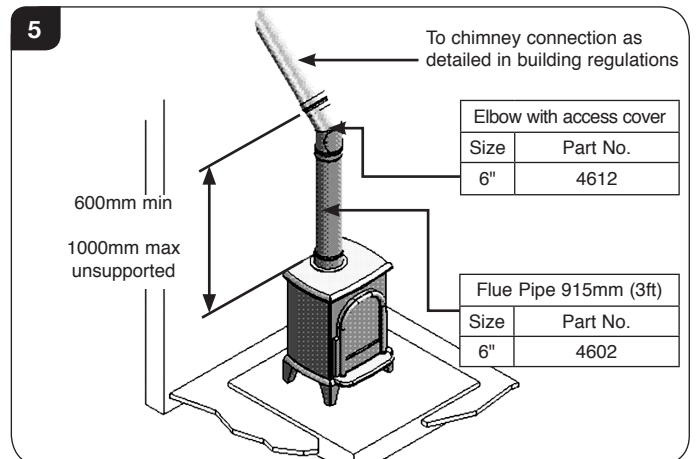
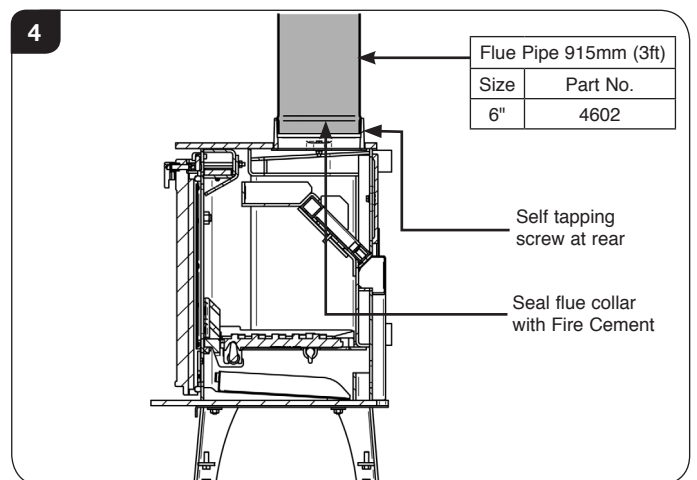

1.4 **Rear flue pipe installation**

- Insert a tee into the flue collar. The tee piece is used as cleaning access.
- Lift appliance into position. Take care not to damage the hearth finish.

i † England and Wales – Document J / Scotland - Part F/Document J (Republic of Ireland only)
‡ the latest edition of BS 8303, BS EN 15287, BS 7566

Installation Instructions

- Level the appliance.
- Connect tee to the chimney using flue pipe.
- Secure with self tapping screw.
- Seal the connecting joints with fire cement.

Do not use a 90° elbow to make this connection.

The Flue must be installed in accordance with manufacturers instructions.

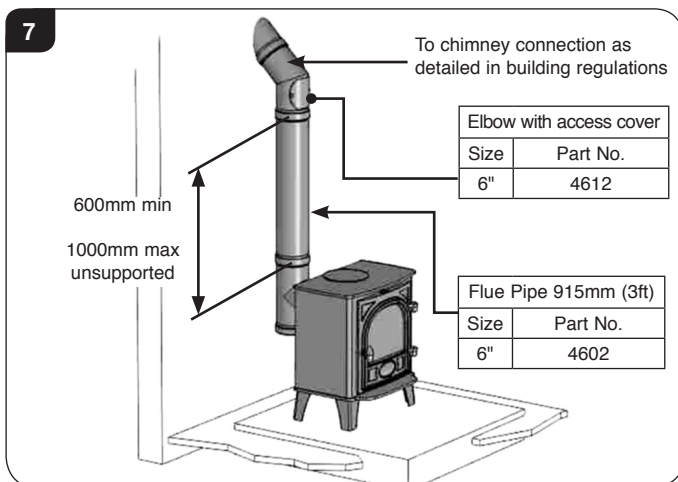
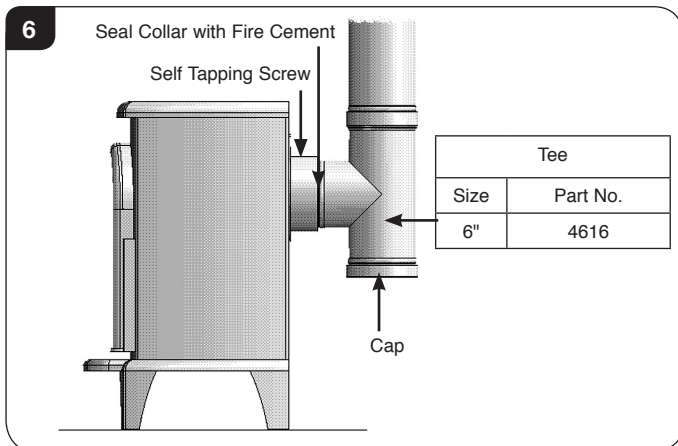

4. CO Alarms

All open flued appliances can be affected by temporary atmospheric conditions which may allow fumes to enter the house. **Building regulations require that whenever a new or replacement fixed solid fuel or wood/biomass appliance is installed in a dwelling a carbon monoxide alarm must be fitted in the same room as the appliance. Further guidance on the installation of the carbon monoxide alarm is available in the latest edition of BS EN50292 and from the alarm manufacturer's instructions.**

HETAS recommend the unit is permanently fixed in accordance with the manufacturer's installation instructions or with the guidance contained in Approved Document J where no other information is available.

Provision of an alarm must not be considered a substitute for either installing the appliance correctly or ensuring regular servicing and maintenance of the appliance and chimney system.

CENTRAL HEATING SYSTEM



When designing a heating system in the UK the following standards must be observed:

- BS EN 14336:2004 Heating Systems In Buildings, Installation & Commissioning of Water Based Heating Systems.
- BS EN 12828 2003 Heating Systems in Buildings, Design of Water Based Heating Systems.
- BS EN 12831: 2003 Heating Systems in Buildings, Method for Calculation of the Design Heat Load.

1. General

This appliance gives out heat in two ways:

- Directly into the room in which it is fitted through convection and radiation.
- Hot water to heat radiators and domestic hot water.

The installation must comply with building regulations and use best practice advice.



IMPORTANT:
FAILURE TO ADD AND MAINTAIN A SUITABLE CORROSION INHIBITOR IN THE BOILER WATER CIRCUIT MAY INVALIDATE YOUR PRODUCT WARRANTY.

2. Boiler Sizing

2.1 It is very important to determine the correct size of appliance for the house:

- Too big a boiler will run too hot and will not be efficient.
- Too small a boiler will not maintain the desired temperature.

2.2 Size the boiler correctly by calculating the following heat loads:

RADIATORS - the amount of heat required to run the radiators efficiently. The correct size of radiator depends on the required temperature for the room, the room heat losses and the radiator manufacturer's guides.

HOT WATER - the amount of heat required to provide the desired amount of domestic hot water.

LOSSES – the amount of heat lost in pipe work - typically 10% of the combined radiators and hot water loads. There are national guidelines for calculating these figures*.

2.3 Careful consideration must be given to where the appliance is fitted. It must be sized correctly for the heat load required and the size of the room. These requirements can be found in the *Installation Checklist*.

2.4 All Kensal appliances are thermostatically controlled. The burning rate is adjusted to the demands of the connected heat load. If the radiators do not require heat then the thermostat will act to shut down the appliance and the direct heat output to the room where it is fitted will reduce (see heat output graph on page 15 to show the ratio between direct heat output and water heat output). To prevent the room becoming too cold, fit a thermostatically controlled radiator as well as the appliance.

Installation Instructions

3. Hot Water Cylinder

- 3.1 The domestic hot water cylinder must be an indirect vented double feed type to meet national standards** and should have a minimum capacity of 117 litres. Houses with more than one bathroom or a separate shower will need a bigger tank.

Fully insulate the tank.

The water draw off pipes to the taps should be in a dead leg connection from the vent pipe.

4. Open Vent & Cold Feed System

- 4.1 This system must be fitted with a minimum of 22mm diameter open vent discharging into a heat resisting feed and expansion tank. There must be at least 25mm air gap between the end of the pipe and the water level. The cistern tank should have an overflow with a minimum diameter of 22mm.

The cold feed must be a minimum 22mm and enter the system as the last connection on the common boiler return.

The open vent and cold feed must not be fitted with any valves, manual or automatic.

Do not use plastic pipe in any part of the flow and return.

5. Heat Leak Radiator

- 5.1 A heat leak radiator must be fitted in the gravity circuit to dissipate any excess heat produced from the boiler when connected demand is low. The domestic hot water cylinder may not be able to disperse heat at all times due to modern insulation. This radiator is commonly fitted in the bathroom and should be rated at 2kW (6500 btu) or 10% of the total boiler output.

This radiator ensures that the appliance is not shut down completely for long periods resulting in the fire going out.

Fit the heat leak radiator in the gravity circuit using 22mm pipe reducing to 15mm for no more than 300mm before the radiator.

Fit the radiator with two 'lock-shield' valves that are set in the fully open position and cannot be shut down. Use diagonal connections. Do not fit thermostatic valves or manually adjustable valves to the heat leak radiator.

6. Pump

- 6.1 Where a pump is fitted into the circuit it should be adjustable so that the flow can match the system requirements. Fit isolation valves to enable removal for servicing. The pump must have at least 1.5 meters of static head.



In the UK:

† England and Wales - Document (/ Scotland - Part N/ Building Regulations

‡ BS7671

* See BS 5449:1

** See BS 1566 Part 1 grade 3 minimum

Registered body: HETAS (GB only)/ INFO (Eire)

7. Electrical Supply

- 7.1 Electrical connections must meet the requirements of national Building Regulations† and standards‡, along with any European, local regulations and working practices that may apply. Should conflict occur between these instructions and these regulations then the regulations must be followed.

The connection to the mains supply should allow complete electrical isolation and only serve the heating circuit pump.

All water connections should be completed by a competent person to meet the requirements of local water authority by-laws.

CONVENTIONAL PIPEWORK SYSTEMS

All pipe work must be able to operate at above 100 degrees Celsius. Any pipe work installed in an exposed position e.g. loft space must have provision to prevent freezing.

Ensure the pipe work system has sufficient drain points to enable the complete removal of water for the purposes of servicing.

8. Gravity Pump Circuit

- 8.1 To prevent the risk of boiling it is essential to arrange the pipe work and position the hot water cylinder and heat leak radiator so that gravity circulation can take place when the pump is not running. Position the cylinder and the radiator vertically above the boiler with sufficient height to encourage gravity flow.
- 8.2 Horizontal pipe work in a gravity system must have an incline of at least 5mm in every 1000mm and a minimum diameter of 28mm. Vertical pipe must have a minimum diameter of 22mm.
- 8.3 Any motorised valves fitted in this circuit must return to the fully open position when the power is interrupted.

9. Pump Assisted Central Heating

- 9.1 The most common arrangement is to have a pumped central heating circuit combined with a gravity hot water circuit. This arrangement requires careful balancing of the two in order to avoid the gravity circuit being starved when the pump is running.

To overcome this problem it is common practice to fit an injector tee where the pumped central heating return re-joins the gravity return from the hot water cylinder. This injector tee induces a much stronger gravity flow when the pump runs.

Only use proprietary injector tees, homemade ones are difficult to get right.

- 9.2 When installing a system that has pumped central heating and gravity hot water it is recommended to use all 4 boiler tapings. Each flow and return should be diagonally opposite each other.

Installation Instructions

Typical layout of a pumped central heating hot water circuit with gravity

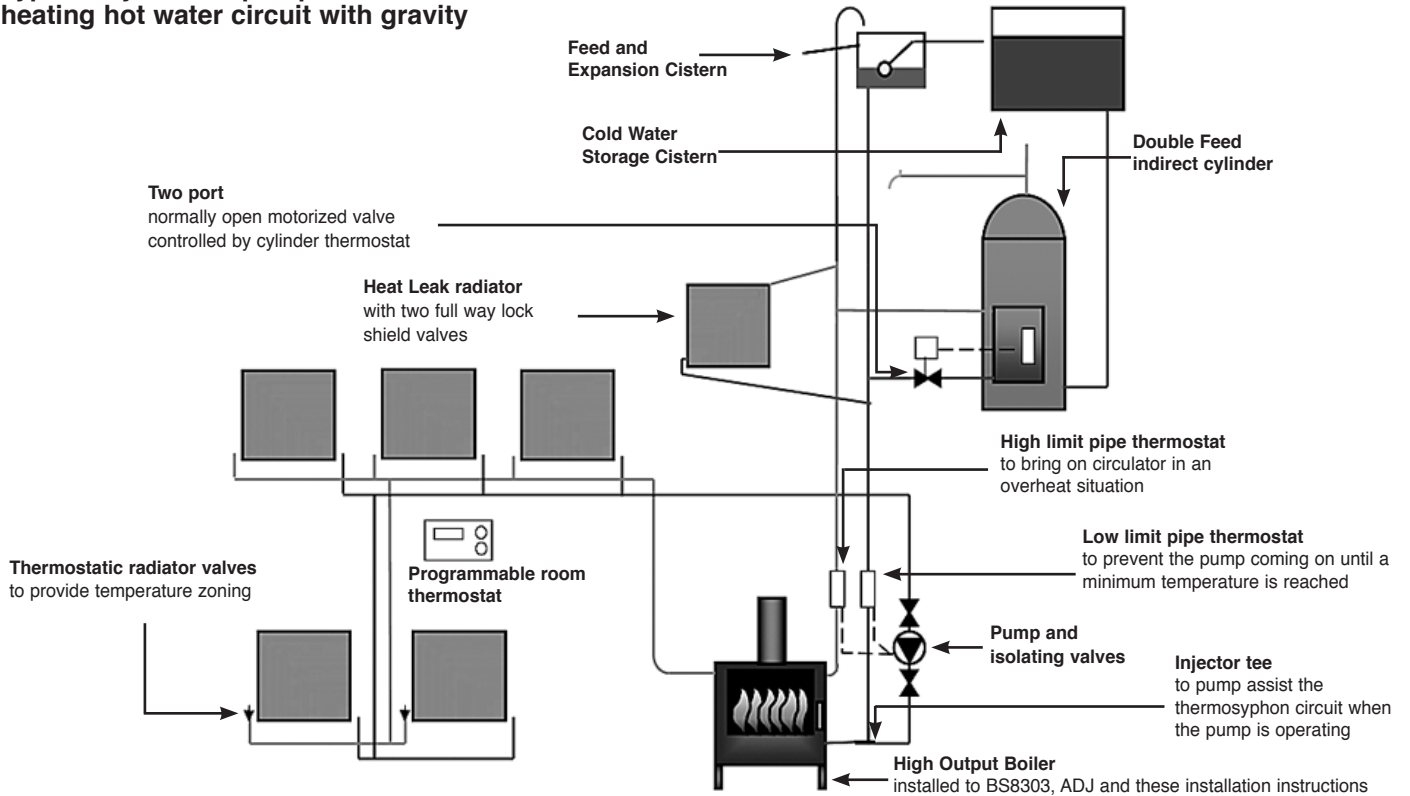

Typical layout of a pumped central heating and hot water circuit

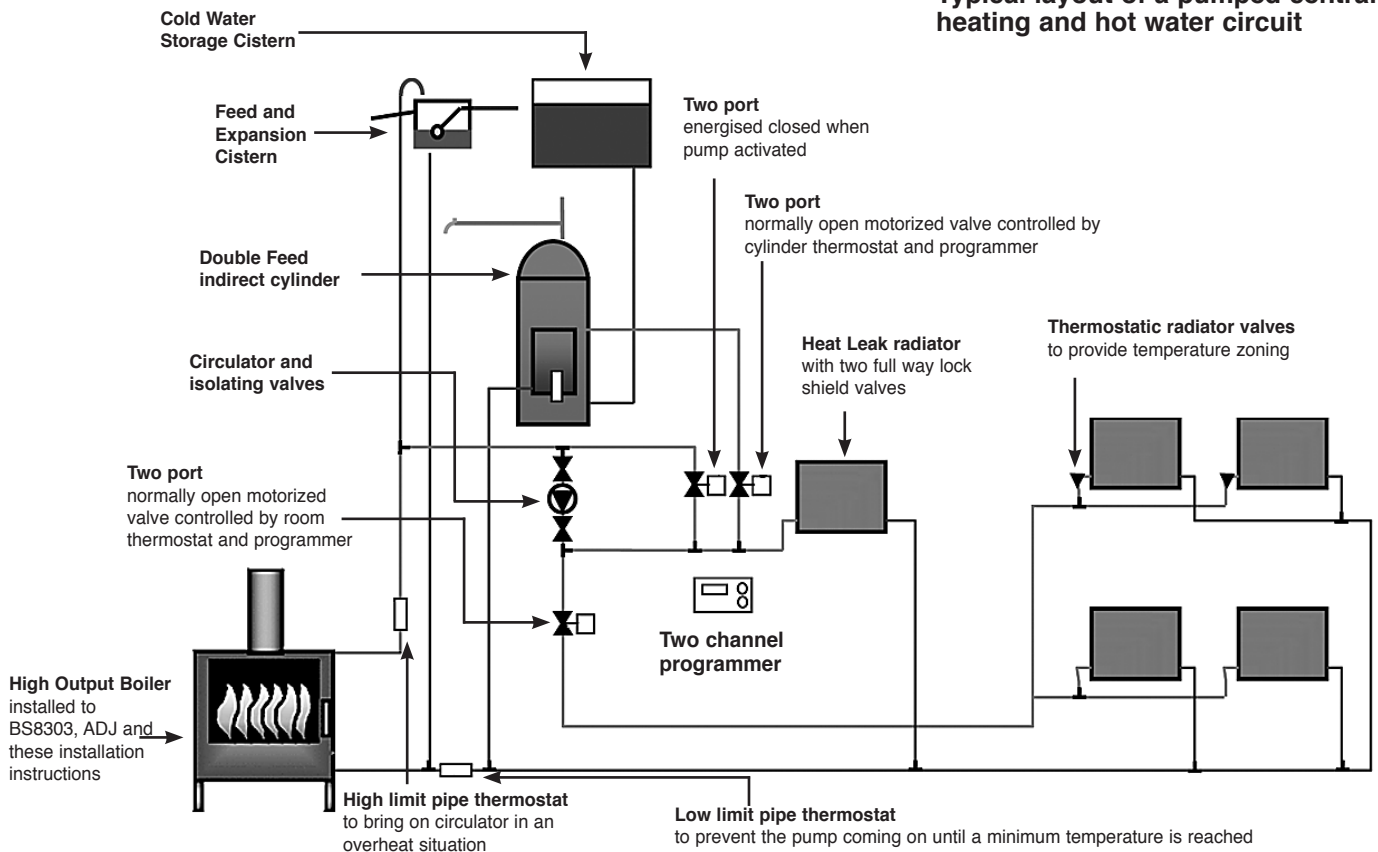

Installation Instructions

10. Fully Pumped System

- 10.1 In many installations (especially new build) a fully pumped system is the best choice to give increased control.

WARNING - To prevent the risk of boiling it is essential to arrange the pipe work and position the hot water cylinder and heat leak radiator so that gravity circulation can take place when the pump is not running. Any motorised valves fitted in this circuit must return to the fully open position when the power is interrupted.

11. Sealed (Pressurized) System

- 11.1 Do not fit this appliance to sealed or pressurised systems or an unvented hot water cylinder.

12. Pipework Diagrams

- 12.1 See below for a typical layout of a pumped central heating and gravity hot water circuit.

HEATING SYSTEM CONTROLS

CONTROLS GENERAL

- 1.1 The controls fitted to the system will provide two functions:
- To control the comfort level in the house.
 - To maintain safety in the event of misuse or mechanical failure.

COMFORT CONTROLS

- 1.2 This primarily consists of a time clock wired into the pump. The pump is switched on when heat is required and when it is not, the pump is switched off.

The time clock, when combined with a room thermostat and or thermostatic radiator valves, enhances the comfort levels in the house.

Some room thermostats combine the function with the time clock and can be programmed to reduce the room temperature rather than turning the system off. This is effective in not allowing the rooms to become too cold and speeding up recovery time.

- 1.3 The hot water cylinder can also be fitted with a thermostatic valve which turns off the flow when the cylinder has reached the desired temperature but the heat leak radiator will have to be bigger to cope with the extra load when the tank is isolated.

SAFETY CONTROLS

- 1.4 This primarily consists of a high limit thermostat fitted to the gravity flow pipe set at 80°C, this thermostat should be connected to the pump so that the pump is turned on if the temperature exceeds 80°C. This will prevent accidental boiling in the gravity circuit.

- 1.5 It is also recommended to fit a low limit thermostat on the central heating return set at 45°C, this thermostat will turn the pump off if the return temperature falls below 45°C. This will prevent corrosion and condensation within the appliance.

CONDENSATION

- 1.6 When filling the boiler with water for the first time, the cold water entering the water jacket can cause condensation to form on the surfaces of the appliance (inside and outside).
- 1.7 In certain conditions this condensation could result in a considerable amount of water, in some cases enough to fill the bottom of the appliance. This could be even worse if the house has recently been re-decorated, wet plastered or any other work has been undertaken which could result in high humidity.
- 1.8 Precautions must be taken to ensure that this build up of condensate does not overflow from the appliance onto any surrounding fabric of the room e.g. carpets.

NOTE - THIS CONDENSATION IS NORMAL DURING FILLING AND DOES NOT INDICATE A FAULTY OR LEAKING APPLIANCE.

NORMAL RUNNING

- 1.9 During normal running this condensation should be minimal if the system is fitted with the low limit thermostat as detailed in 1.5. This low limit thermostat prevents the system pump from running until the appliance has reached temperature.

SEASONAL USE

- 1.10 If this appliance is unused for lengthy periods of time it should be periodically checked to ensure that condensation is not building up within the appliance.

NOTE – THIS CONDENSATION IS NORMAL AND DOES NOT INDICATE A FAULTY OR LEAKING APPLIANCE.

If the appliance is going to be unused for very long periods of time it is recommended to drain the system.

NOTE – Further information on solid fuel central heating systems can be found in the HETAS engineers training manual.

LINK UP SYSTEMS

For information on how to link solid fuel boilers to other heating appliances see Information For Dual System Link Up Methods (PM286). This can be obtained through Kensal.

Call (01392) 474011, email info@stovax.com or visit www.kensalstoves.com for details.

Always seek the advice of a competent person* before linking another heating system to a solid fuel boiler.



***Registered on the Competent Persons Scheme (GB only) see page 39/ INFO (Republic of Ireland).**

Commissioning

1. Commissioning

- 1.1 To commission:
- Replace the internal components.
 - Check the door alignment and catch operation, adjust if required, see Maintenance & Servicing, Sections 6 & 7.
 - Check the soundness of door seals, castings and joints.
 - Check the operation of the air controls.
 - Ensure the system has been filled with water and includes a suitable inhibitor.
- 1.2 Now carry out a final smoke draw test:
- First warming the flue with a blowlamp, or similar, for about 10 minutes.
 - Place a smoke pellet on the centre of the grate, with the air controls open.
 - Close the door. Smoke should now be drawn up the flue and be seen to exit from the flue terminal.
 - Complete test with all doors and windows closed in the room where the appliance is fitted.
 - If there are any extractor fans in adjacent rooms, the test must be repeated with the fans running on maximum and interconnecting doors open.
 - Check the effect of ceiling fans during the test.

If the test fails, re-check the suitability of the flue system and ventilation. An inadequate air supply to the room is potentially dangerous.

- Light the appliance and slowly increase the temperature to operating levels.
- Ensure no combustion products enter the room.
- Open the main fire door when the appliance reaches operating condition and carry out a spillage test with a smoke match or pellet around the door opening.
- Run the system up to temperature.

BALANCING THE SYSTEM

It is essential to balance the central heating system in order to achieve an even heating performance across all of the radiators in the house. Balanced means each radiator having a 10°C difference in temperature between the flow and the return, ideally 80°C flow and 70°C return.

Have the system running and adjust the appliance thermostat so that the flow temperature measured near the appliance is approximately 80°C. Ensure that all valves including lock-shield valves are in the fully open position and the pump is at its estimated correct speed. If there are thermostatic radiator valves, have these on maximum setting and ensure that they do not activate.

Ensure that the radiators have been bled of air.

Write down the return temperature of each radiator in turn and its difference to the flow temperature at the appliance. Make sure that the flow temperature remains constant.

The radiator with the greatest difference (the index radiator) and any other radiator within 1 degree should be left with the lock-shield fully open. The remainder of the lock-shield valves should be closed to about 1/3 open. Leave the system to stabilise, this could take some time.

When the system has stabilised, write down the new difference between the flow and return temperatures and any which differ from the index radiator by more than 1 degree will need further adjustment, some valves will have been closed too much and others not enough, usually the adjustments need to be only a fraction of a turn at a time. Leave sufficient time for the system to stabilise after each adjustment.

When the radiator temperatures are starting to become consistent, but before final adjustments, the index radiator needs to be considered, if the return temperature of this radiator is not near 70 degrees then the pump will need to be adjusted to either provide more (to increase the temperature) or less flow to decrease the temperature. Again, sufficient time will need to be left to allow the system to stabilise after adjusting the pump speed.

When the radiator flow and return temperatures are correct the final adjustments can be made and the lock-shield covers replaced.

Knowing how far to shut down a valve to get the desired change in flow and return temperature, and knowing how long to wait for the system to stabilise, takes a little time and practice.

- 1.3 If excessive spillage occurs:

- Allow the appliance to cool and re-check the flue system and ventilation.

- 1.4 **Finally:**

- **Explain the safe operation of the appliance and the use of the controls to the user and the importance of only using suitable fuels.**
- **Ensure that a thermostat has been fitted and make the user aware of its operation and importance.**
- **Ensure that a CO alarm has been fitted and make the user aware of its operation and importance, referring them to the Warning section on page 6 of the User Instructions.**
- **Explain the cleaning and routine maintenance requirements.**
- **Explain the requirement to use a suitable fireguard when children, elderly or infirm persons are near the appliance.**
- **Record dealer/supplier and installer details in *Appliance Commissioning Checklist* (page 3, Instructions for Use).**
- **Record serial number in *Appliance Commissioning Checklist* (page 3, Instructions for Use). This number is required when ordering spare parts and making warranty claims.**
- **Give the copy of the *Instructions* to the customer.**



BS EN 14336:2004 Heating Systems In Buildings, Installation & Commissioning of Water Based Heating Systems.

Certificate Of Compliance

Upon completing the installation, the form below must be filled in by your installer to comply with the requirements of HETAS and the building regulations. The installer must give these details, including their HETAS registration number, for the purposes of any insurance details that may change as a result of the appliance being installed.

HETAS LTD - CERTIFICATE OF COMPLIANCE

PLEASE TICK APPROPRIATE BOXES OR ENTER DETAILS IN BOXES BELOW



Record ID (HETAS Use Only)	<input type="text"/>	(*indicates that this data must be given)
Customer Name	*	
Installation Address	*	
Installation Address		
Installation Address		
Installation Address		
Town	*	
Postcode	*	Work Completion Date *
Local Authority Name (*Must be given if no postcode available)		
Installing Company Name	*	Company's HETAS Reg. No. *
Installing Engineer's Name	*	Engineer's HETAS Reg. No. *

Description of Work

Location:
 Lounge Dining Room Kitchen Utility Room Bedroom Other, Specify

Appliance: Dry Open Fire Open Fire with Boiler Dry Cooker Cooker with Boiler
 Dry Roomheater/Stove Roomheater/Stove with Boiler Independent Boiler
 Make Model Heat Output kW

System: New Heating and Hot Water System Updated Existing Heating and Hot Water System Dry System Only

If Wet System: Is the Hot Water System Unvented? Y N

Chimney: New Insulated Factory Made Chimney System Installed

Relining of existing chimney: Twin Wall Flexible Liner (for Class 1 Appliance) Cast In-situ Liner
 Rigid Sectional Liner Metal Rigid Sectional Liner Other

Hearth: New Hearth/Surround fitted Existing Hearth Surround Updated

Additional Information

Connecting fluepipe: Diameter mm Socket joints upward and gas tight

Provision for sweeping chimney/fluepipe: Yes No Chimney Data Plate Location

Air supply: Has a permanently open air vent been fitted: Yes No
 Is vent opening at least 50% of cross sectional area of throat/flue or State total free area of air vent mm²

Confirm an approved Carbon Monoxide alarm has been fitted

Testing & Commissioning to Approved J Appendix E

Confirm you have commissioned and tested the appliance & associated work for safe and efficient operation

Declaration of completion As the competent person responsible for the work described above, I confirm that the appliance and associated work has been installed in accordance with the HETAS rules of registration, and that the work complies with Regulations 4 and 7 of the Building Regulations, and Approved Documents J, G & L as applicable.

Signed: _____ Print name: _____ Date: _____

COPIES OF THIS COMPLETED CERTIFICATE MUST BE (WHITE COPY) SENT TO HETAS LTD AT THE ADDRESS GIVEN BELOW (PINK COPY) GIVEN TO THE CUSTOMER FOR RETENTION (YELLOW COPY) RETAINED BY THE INSTALLING COMPANY

**THIS CERTIFICATE SHOULD BE RETAINED BY THE PROPERTY OWNER
WHO MAY BE REQUIRED TO PRODUCE IT IN ANY FUTURE SALE OF THE PROPERTY.**

Maintenance & Servicing

For a complete list of spare parts and accessories contact your Kensal retailer or call 01392 474011

1. Annual Service



IMPORTANT: Kensal provide gauntlet style gloves for the users protection from heat and any sharp edges when using the appliance. For your safety ensure that gloves are always worn when opening, operating, refuelling or handling internal metalwork.

- 1.1 Before the start of the heating season strip, inspect and clean the appliance as detailed:
- Allow appliance to cool.
 - Remove all internal parts: baffle, log guard, Secondary Air Chamber and grate system.
 - Remove the Woodburning tray (if fitted), see Maintenance & Servicing Section 3. Clean with a wire brush. **When removing the tray ensure no ash falls behind the ash guard at the back of the firebox.**
 - Sweep the appliance at this point if necessary.
 - Clean the internal surfaces of the appliance using a wire brush and scraper as required. Vacuum and brush the resulting debris from the appliance.
 - Clean the grate parts with a wire brush.
 - Vacuum clean any remaining ash and debris from the inside of the appliance. Stovax offer a filter/collection attachment for vacuum cleaners to protect them from fire ash: Ash Clean (Part No. 2091).
 - Check the parts for any damage. Replace any damaged parts using genuine Kensal replacements parts.
 - Re-fit cleaned internal parts.
- On appliances with printed glass do not use cleaning agents that have a high alkaline or acidic content, for example Stovax Gel Cleaner, these are aggressive cleaning agents designed to be used with heavily stained clear glass. On printed glass surfaces, use Stovax Glass Cleaner (Part No.4103) which is better formulated for this application.**
- Do not use abrasive cleaners to remove tar or soot deposits from the glass.**
- Fit new door rope seal (see *Maintenance and Servicing, Section 5*).
 - Lightly oil the door catch mechanism and hinge pins. Avoid getting oil onto the door seals and glass.
 - To refresh painted finishes a touch up spray is available. Contact your Kensal retailer quoting the serial number found on the appliance date badge.

- 1.2 Use genuine Kensal replacement parts to keep the appliance in safe, efficient working order. This is a list of the maintenance products that may need be required:

Task	Product name
Preventing build-up of creosote in flue	Protector (15 sachets)
	Protector (1kg tub)
Sealing flue pipe joints	Fire Cement (500g tub)
	Fire Cement (600g cartridge)
Re-painting	150ml Touch up aerosol
Protecting your hands	Heat resistant leather gloves
Thermic seal glue	(50ml bottle)
Ash Clean	Vacuum Cleaner Attachment
Cleaning Glass	Gel Cleaner
	Glass Cleaner (Part no. 4103)

These products, available online at www.stovax.com or from your local Kensal Retailer, along with regular maintenance and use of correct fuels, will keep the appliance in the best possible condition.

- 1.3 Burn at a low temperature for the first day of use after any maintenance. This allows the seals, fixing glues and paint to fully cure.
- 1.4 During this time the appliance may give off some unpleasant odours. Keep the room well ventilated to avoid a build-up of fumes.
- 1.5 Your Kensal Retailer can carry out service and maintenance.

2. Removal of Internal Parts

- 2.1 To service and maintain the good working condition of your appliance it will be necessary to remove several internal parts. Consult the installation section for the following:
- Log Guard** - Pre-Installation Section 2, page 22.
 - Baffle** - Pre-Installation Section 3, page 22.
 - Secondary Air Chamber** - Pre-Installation Section 4, page 23.
 - Riddling Mechanism** - Pre-Installation Section 5, page 24.

Maintenance & Servicing

3. Removing the Woodburning Tray (if fitted)

To maintain safe use of the appliance the Woodburning tray should be removed and cleaned regularly.

- 3.1 Remove the log guard and ashpan.
- 3.2 Remove ash from the Woodburning tray with a small shovel and place into a Ash Caddy (Part No. 4227) or other suitable container.
- 3.3 Lift one side of the tray and rotate out through the front of the appliance, see Diagram 1.

Ensure no ash falls behind the ash guard at the back of the firebox.

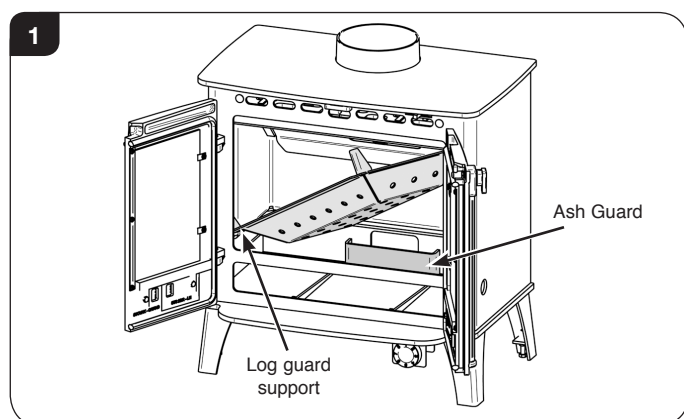

- 3.4 Clean with a wire brush.
- 3.5 Replace in reverse order.

When replacing the Woodburning tray ensure that the lower log guard support is inserted first to achieve the correct angle, see Diagram 1.

4. Fitting a new Door Glass

To maintain safe use of the appliance damaged door glass must be replaced immediately.

To do this:

- 4.1 Remove the door by opening and lifting the door free of the hinge blocks. Note the hinge pins are fixed to the door castings.
- 4.2 Lay the door face down on a soft flat surface to protect the paintwork and glass.
- 4.3 Remove the glass clips fixing screws. The old glass can then be lifted clear of the door.

Note how the 3mm sealing rope is placed between the glass and the door.

- 4.4 **Dispose of the old glass safely.**

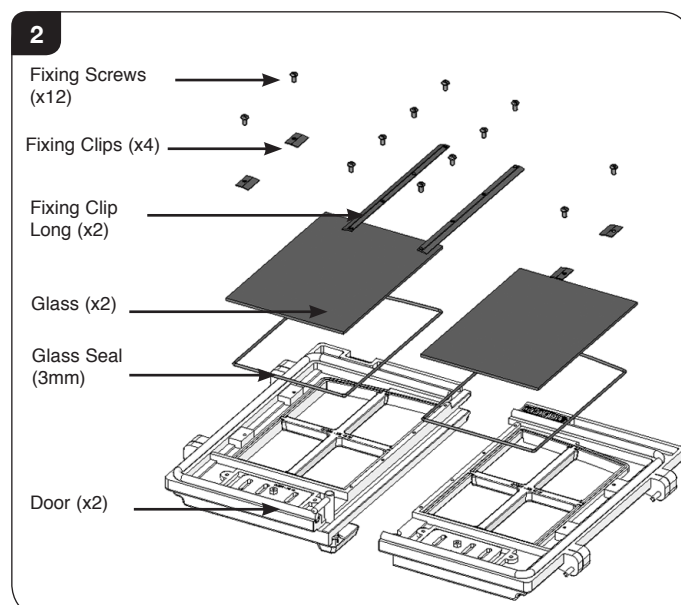

- 4.5 Clean and re-paint the rear of the door if required.
- 4.6 Clean the screws with light oil and coat with high temperature anti-seize grease to aid future removal.
- 4.7 Fit a new sealing rope and place the glass into position in the door.
- 4.8 Place the glass fixing clips into position and re-fix with the clean fixing screws, tightening the screws evenly until glass is held securely.

Do not over tighten the screws as this could break the glass.

- 4.9 Fit only original Kensal ceramic glass, which is suitable to use in high temperature applications.
- 4.10 Using the appliance with damaged door glass could cause dangerous fumes to enter the room or the appliance to over-fire resulting in damage.

Maintenance & Servicing

5. Fitting a new Door Seal

To maintain the safe use of the appliance damaged or worn door sealing rope must be replaced.

To do this:

- 5.1 Remove the door by opening and lifting the door free of the hinge blocks. Note the hinge pins are fixed to the door castings.
- 5.2 Lay the door face down on a soft, flat surface to protect the paintwork and glass.
- 5.3 Remove old rope and scrape old glue from locating groove.

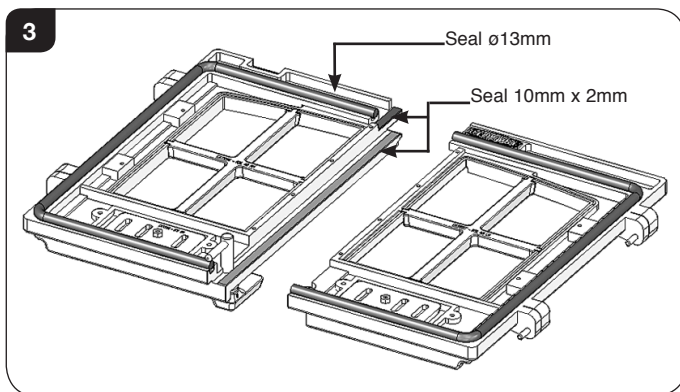

- 5.4 Clean the locating groove with a clean, dry cloth to remove all old dust and debris.
- 5.5 Squeeze a generous bead of fresh Thermic Seal glue into the rope locating groove (part no. 5037).
- 5.6 Press the new rope into the locating groove placing the joint in the middle of the lower edge of the door.
- 5.7 Refit the door and close to apply pressure on the new rope.
- 5.8 Leave the door(s) closed for at least 12 hours before lighting the appliance and run at a low temperature for approximately one day. This allows the adhesive to fully bond to the seal.
- 5.9 Using the appliance with a damaged door seal can cause dangerous fumes to enter the room, or the appliance to over fire resulting in damage.

6. Adjusting the Door Hinges

6.1 To maintain the safe use of your appliance, you may need to adjust the door hinges to ensure the door closes safely and correctly.

6.2 To complete this operation:

Open the door to give access to the fixed part of the door hinge as shown.

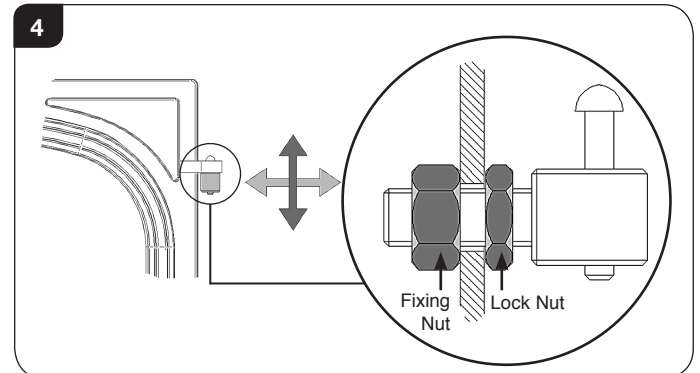

Use a 19mm A/F spanner to loosen the fixing nuts.

6.3 Reposition the hinge blocks to achieve a correct fit. This may require several adjustments to find the correct position.

Once the desired position has been achieved ensure the fixing nuts are firmly tightened to maintain the position.

7. Adjusting the Door Catch

Alterations should only be carried out by a competent person if the door does not effectively seal and adjustment is required.

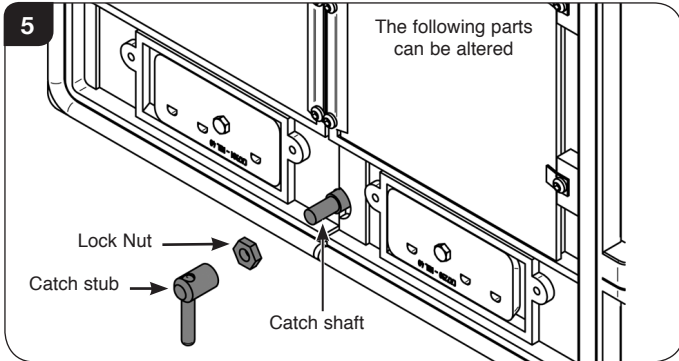

- 7.1 The door catch can be adjusted as required to move the door in or out to achieve effective sealing. It is also possible to adjust the catch to ensure the handle aligns vertically when shut.
- 7.2 The catch is held in place by a screw thread which can be turned to tighten or loosen. Following alteration ensure the stub sits vertically to ensure a vertical position when the door is shut and lock the nut and catch stub tightly together.

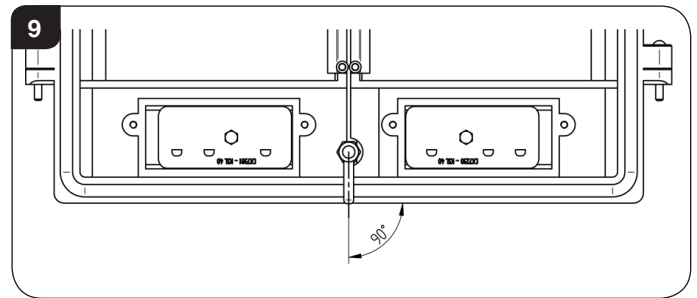
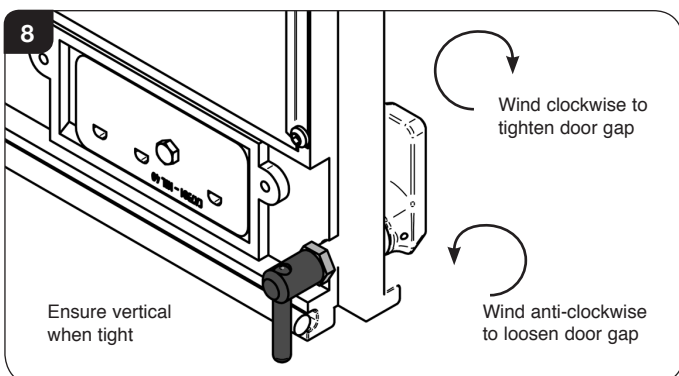
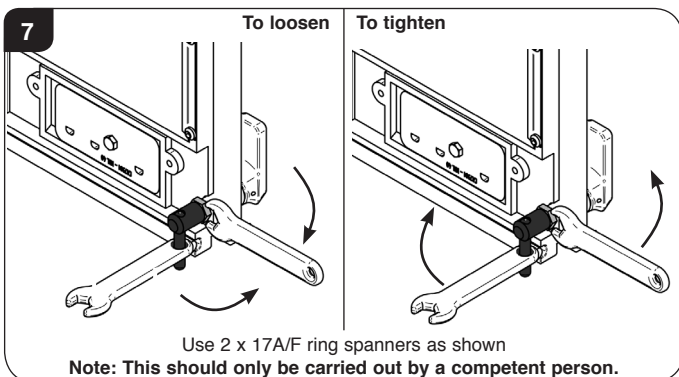

Technical Appendix

Legal Requirements

Before installation and/or use of this appliance please read these instructions carefully to ensure that all requirements are fully understood.

The appliance must be fitted by a registered installer, or approved by your local building control officer.

It is very important to understand the requirements of the national Building Regulations† and standards‡, along with any local regulations and working practices that may apply. Should any conflict occur between these instructions and these regulations then the regulations must apply.

Your local Building Control Office can advise regarding the requirements of the regulations.

i † England and Wales – Document J / Scotland - Part F/Document J (Republic of Ireland only)
‡ the latest edition of BS 8303, BS EN 15287, BS 7566

***Registered on the Competent Persons Scheme (GB only) see page 39/ INFO (Republic of Ireland).**

Works must be carried out with care to meet the requirements of Health and Safety and comply with the Health and Safety rules, and any new regulations introduced during the lifetime of these instructions. Particular attention should be drawn to:

- **Handling:** The appliance is heavy. Adequate facilities must be available for loading, unloading and on site handling.
- **Fire Cement:** Some fire cement is caustic and must not come into contact with the skin. Protective gloves must be worn. Wash hands thoroughly with plenty of water after contact with skin.
- **Asbestos:** This appliance contains no asbestos. If there is the possibility of disturbing any asbestos in the course of installation seek specialist guidance and use appropriate equipment.
- **Metal Parts:** Take care when installing or servicing the appliance to avoid personal injury.

A faulty installation can cause danger to the inhabitants and structure of the building.

For users of this appliance:

Your building insurance company may require you to inform them that a new heating appliance has been installed on your property. Check that your cover is still valid after installing the appliance.

Flue Outlet Positions

These positions are defined by Document J of the Building Regulations.

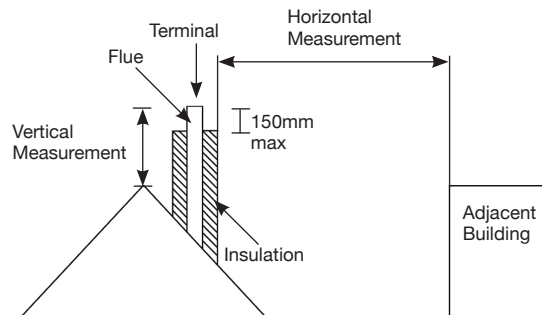
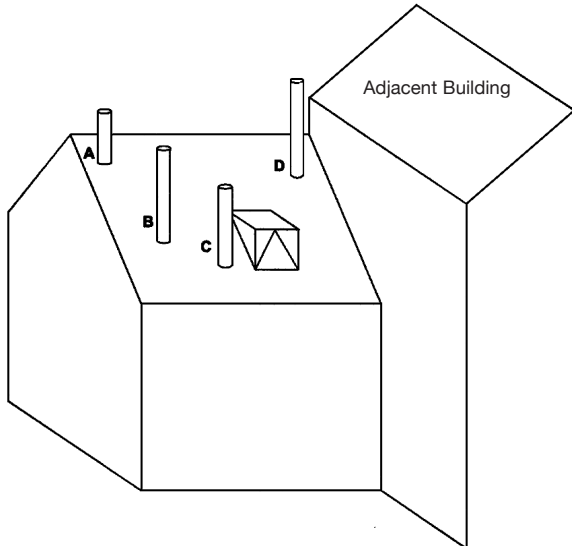

The datum for vertical measurement is the point of discharge of the flue from either the point of discharge of the flue or 150mm above insulation, whichever is the lower.

IMPORTANT: Seek specialist advice if installing in a dwelling with a thatched roof

Point where the flue passes through weather surface (Notes 1 & 2)		Clearances to flue outlet
A	At or within 600mm of the ridge	At least 600mm above ridge
B	Elsewhere on roof (whether pitched or flat)	At least 2300mm horizontally from the nearest point on the weather surface and: a) at least 1000mm above highest point of intersection of the chimney and the weather surface; or b) at least as high as the ridge
C	Below (on a pitched roof) or within 2300mm horizontally to openable rooflight, dormer window, or other opening (Note 3)	At least 1000mm above the top of opening
D	Within 2300mm of an adjoining or adjacent building, whether or not beyond the boundary (Note 3)	At least 600mm above any part of the adjacent of building within 2300mm

- 1) The weather surface is the building external surface, such as it's roof tiles or external walls.
- 2) A flat roof has a pitch less than 10°.
- 3) The clearance given for A or B, as appropriate, will also apply.
- 4) A vertical flue fixed to an outside wall should be treated as equivalent to an inside flue emerging at the nearest edge of the roof.

2. Flue or Chimney

2.1 The flue or chimney system must be in good condition. It must be inspected by a competent person and passed for use with the appliance before installation.

Products of combustion entering the room can cause serious health risks.

2.2 The following must be checked:

— The construction of the masonry chimneys, flue block chimneys and connecting flue pipe system must meet the requirements of the Building Regulations†.

— A flexible flue liner system can be used if certified for use with solid fuel systems and installation complies with manufacturer's instructions and Building Regulations. The flue liner must be replaced when an appliance is replaced, unless proven to be recently installed and in good condition.

— If it is necessary to fit a register plate it must conform to the Building Regulations†.

— The minimum height of the flue or chimney must be 4.5m from the hearth to the top of the flue, with no horizontal sections and a maximum of 4 bends. Bends must have angles of less than 45 degrees from the vertical.

— Ensure the connecting flue pipe is kept a suitable distance from any combustible material and does not form part of the supporting structure of the building.

— The installer must ensure the flue pipe diameter is not less than the diameter of the outlet of the appliance and does not narrow to less than the size of the outlet at any point in the system.

— Make provision to remove the appliance without the need to dismantle the chimney.

— Any existing flue must be confirmed as suitable for the new intended use as defined in the Building Regulations.

— The flue or chimney systems must be inspected and swept to confirm the system is structurally sound and free from obstructions.

— If the chimney is believed to have previously served an open fire it must be swept a second time within a month of regular use after installation to clear any soot falls that may have occurred due to difference in combustion levels.

— The flue exit from the building must comply with local building control rules†.

— Do not connect or share the flue or chimney system with another heating appliance.

2.3 Do not connect to systems containing large voids or spaces over 230mm square.

2.4 Suitable access must be provided to enable the collection and removal of debris.

2.5 The flue must be swept and inspected when the appliance is installed.

Flue Draught

The flue draught must be checked with all windows and doors closed and any extraction fans in this, or adjoining rooms, running at maximum speed (see Installation Checklist for ventilation requirements).

Twin Wall Flue System

If this appliance is to be used in conjunction with a twin wall flue system then Kensal recommend the use of the Stovax Professional XQ range. Details of this product are available from your Kensal retailer.



In the U.K:

*BS EN 15287-1, and the requirements of Building Regulations

**This should be done by a NACS registered (UK only)/INFO registered (Eire only) chimney sweep, who will issue you with a certificate.

† Building Regulations Document J

Flue Plate:

Where a hearth, fireplace, flue or chimney is provided or extended (including cases where a flue is provided as part of refurbishment work), information essential to the correct appliance and use of these should be permanently posted in the building, to meet Requirement J4 of the Building Regulations (England and Wales), F3.12 (Scotland).

Additional:

A new factory made system that complies to EN 1856; Part 1 can be used providing installation is to the requirements of:

- i) BS 7566 Parts 1 -4
- ii) the manufacturer's instructions
- iii) Building Regulations.

For a guide containing information on Chimneys and Flues contact:

The British Flue & Chimney Manufacturers' Association,
FETA
2 Waltham Court
Milley Lane
Hare Hatch
Reading
Berkshire RG10 9TH

Tel: 0118 9403416

e-mail: info@feta.co.uk

Ventilation - Technical Appendix

3. Ventilation

- 3.1 Many older buildings are sufficiently ventilated by natural leakage of air to provide suitable air supply for an appliance of 5kW output or less.

Modern building techniques have reduced the amount of air that leaks in or out of a house. A modern construction with an air tightness of less than 5m³ per hour per m² requires an air vent for **ALL** solid fuel appliances including those with a rated heat output of less than 5kW.

NOTE: The air leakage of a modern house is tested at the completion of construction and a certificate issued confirming this.

- 3.2 This appliance requires a constant supply of air to maintain proper combustion and effective flue performance.
- 3.3 An inadequate air supply can result in poor combustion and smoke entering the room which is potentially dangerous.
- 3.4 This supply of air can come from either:
- Purpose provided ventilation.
- 3.5 The amount of air required must comply with local building regulations and the rules in force.
- 3.6 If spillage is detected during commissioning then there may be insufficient natural ventilation and an additional air supply will be necessary.
- 3.7 Permanent air vents should be non-adjustable and positioned where they are unlikely to become blocked.
- 3.8 If vents open into adjoining rooms or spaces there must be an air vent of at least the same size direct to the outside.
- 3.9 Site the vents where cold draught is unlikely to cause discomfort. This can be avoided by placing vents near ceilings or close to the appliance (See diagram).
- 3.10 Extractor fans or cooker hoods must not be placed in the same room or space as this can cause the appliance to emit fumes into the room.
- 3.11 Increase air supply provisions where a room contains multiple appliances.
- 3.12 **If any checks reveal problems do not proceed with the fitting of the appliance until they have been rectified.**

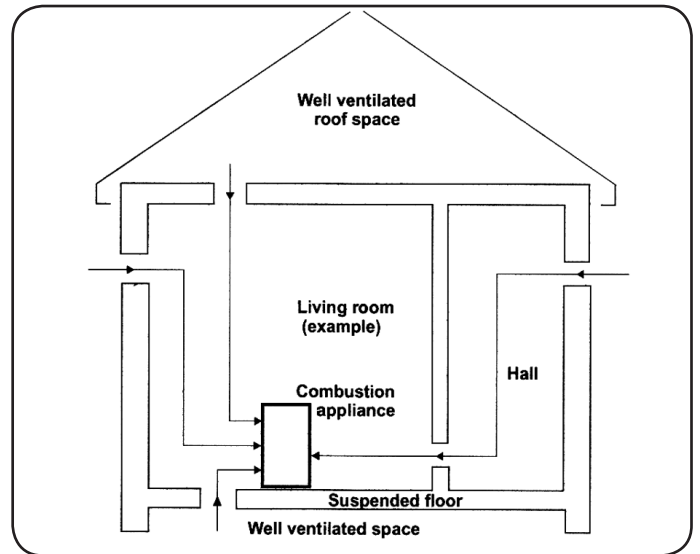

4. Minimum Dimensions - Hearth

- 4.1 The appliance must stand on a non-combustible constructional hearth which is at least 125mm thick with the minimum dimensions as shown in diagram. As this appliance can be installed in an elevated setting it is recommended to increase the 225mm hearth depth to safely contain any falling logs or embers. The higher the appliance is installed the deeper the hearth should be to protect the floor.
- 4.2 The building must have a suitable load-bearing capacity for the hearth and appliance. Consult a structural engineer for advice before proceeding.
- 4.3 When fitting into an existing hearth check that the appliance complies with current construction regulations and is at least the minimum sizes shown.
- 4.4 If there is no existing fireplace or chimney it is possible to construct a suitable non-combustible housing and hearth setting. The flue must be installed in accordance with all local and national regulations and current rules in force.
- 4.5 Check if adding a new chimney to your property requires planning permission.
- 4.6 Some houses are built using a timber frame construction with high levels of thermal insulation. Isolate the appliance from combustible materials, and provide sufficient ventilation to maintain the heating efficiency.

5. Fitting Appliances on a Boat

- 5.1 If an appliance is to be fitted in a boat it must be done in accordance with the latest edition of BS 8511 (Code of Practice for the Installation of Solid Fuel Heating Appliances on Boats). The Code covers the design, installation and operation of solid fuel heating appliances that are suitable for fitting into inland waterway boats, and gives guidance on product selection, design considerations, installation requirements, inspection and testing, as well as maintenance and safe use tips.
- 5.2 Consideration should also be given to the requirements of the Boat Safety Scheme (BSS) to ensure the boat's insurance remains valid.
- 5.3 The appliance should only be installed by a competent person with experience of the latest edition of BS 8511 and the Boat Safety Scheme (BSS).
- 5.4 Secure the product to a suitably constructed non-combustible hearth.
- 5.5 All open flued appliances can be affected by temporary atmospheric conditions which may allow fumes to enter the boat. An electronic carbon monoxide detector conforming to the latest edition of BSEN50292 must be fitted and maintained.
- 5.6 Failure to safely install the appliance could endanger the boat and persons on board.



Organisations authorised to certify competence in the installation of domestic solid fuel appliances (Competent Persons Scheme):

APHC - Association of Plumbing and Heating Contractors (Certification) Ltd.
www.aphc.co.uk

BESCA - Building Engineering Services Competence Accreditation Ltd.
www.besca.org.uk

HETAS - Heating Equipment Testing and Approval Scheme Ltd.
www.hetas.co.uk

NAPIT - National Association of Professional Inspectors and Testers Ltd.
www.napit.org.uk

NICEIC - NICEIC Group Ltd.
www.niceic.org.uk

HETAS Approved Chimney Sweeps:

NACS - The National Association of Chimney Sweeps
www.chimneyworks.co.uk

APICS - The Association of Master Chimney Sweeps Ltd.
www.apics.org

The Guild of Master Chimney Sweeps -
guildofmasterchimneysweeps.co.uk

Information Requirement - Solid Fuel

Product Fiche - Information Requirement for Solid Fuel Local Space Heater

Model	Kensal 40 HO Boiler MF	Kensal 40 HO Boiler W	Kensal 60 HO Boiler MF	Kensal 33 W
Direct Efficiency Class	A	A	A	A
Direct Heat Output (kW)	13.00	13.00	17.00	17.00
Indirect Output (kW)	7.00	7.00	11.00	11.00
Energy Efficiency Index (EEI)	92	92	90	90
Useful Energy Efficiency at Nominal Heat Output	70%	70%	69%	69%
Safety Precautions	Appliance must be installed, Used and Maintained in accordance with the manufacturers instructions supplied			

Basic Spare Parts

KENSAL 60 - RIDDLING ASSEMBLY

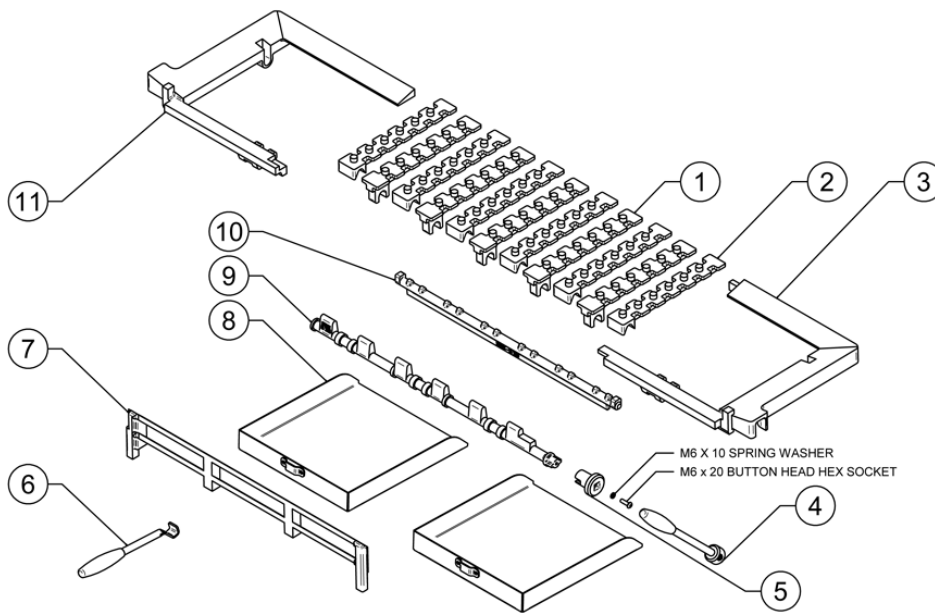

Ref.	Description
1	FIXED GRATE BAR
2	RIDDLING GRATE BAR
3	R/H INFILL
4	RIDDLING TOOL
5	RIDDLING SOCKET
6	ASHPAN TOOL
7	LOG GUARD
8	ASHPAN
9	RIDDLING BAR
10	BACK RIDDLING BAR
11	L/H INFILL

KEN60HBMF2

PR9746-1



Due to continual technical improvements please check online or with your Kensal retailer for the most up to date parts lists.

Only use Genuine Kensal spares when servicing your appliance.

KENSAL 40/ KENSAL 60 MULTI-FUEL HIGH OUTPUT BOILER

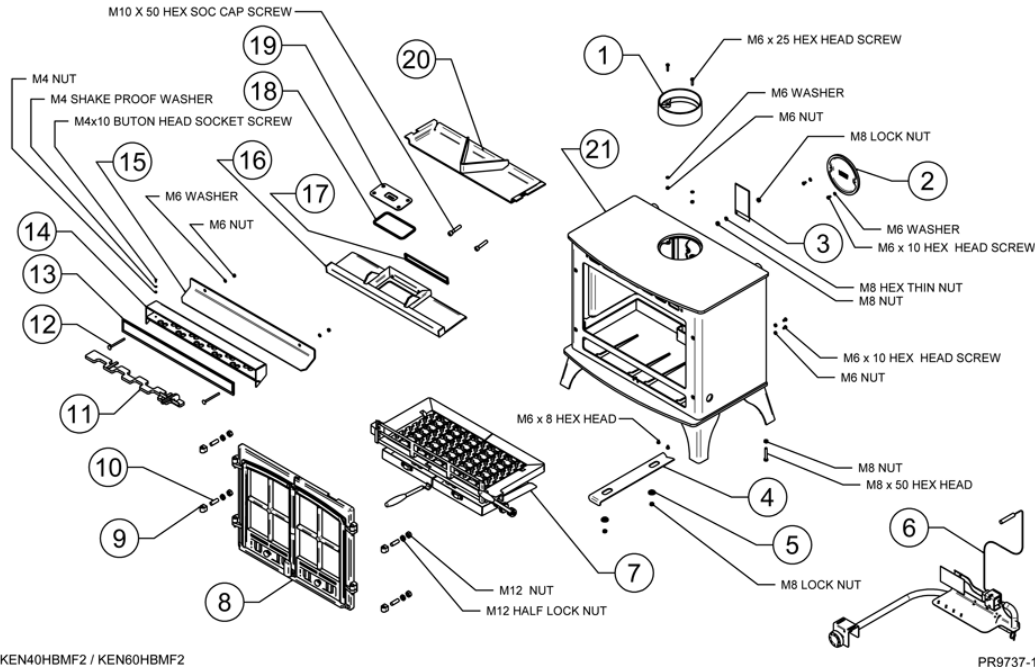

KEN40HBMF2 / KEN60HBMF2

PR9737-1

KENSAL 60 WOOD BURNING HIGH OUTPUT BOILER

Ref.	Description
1	6" FLUE COLLAR
2	6" FLUE BLANKING PLATE
3	DATA PLATE MOUNT
4	CLAMP
5	PLUG
6	THERMOSTAT KIT
7	SECONDARY AIR CONTROL
8	TERTIARY AIR SPACER
9	WOOD BURNING TRAY
10	ASHPAN
11	ASHPAN TOOL
12	LOG GUARD
13	2 DOOR ASSEMBLY
14	HINGE BLOCK
15	M12 X 35 STUD
16	AIRWASH SLIDER
17	M6 X 80 COACHBOLT
18	SELF ADHESIVE FLAT BLACK ROPE
19	AIRWASH CHAMBER ASSEMBLY
20	AIRWASH CHAMBER DEFLECTOR
21	SECONDARY BAFFLE ASSEMBLY
22	SELF ADHESIVE FLAT BLACK ROPE
23	FLAT BLACK ROPE
24	CLEANING PLATE
25	BAFFLE
26	CARCASS - 2 DOOR

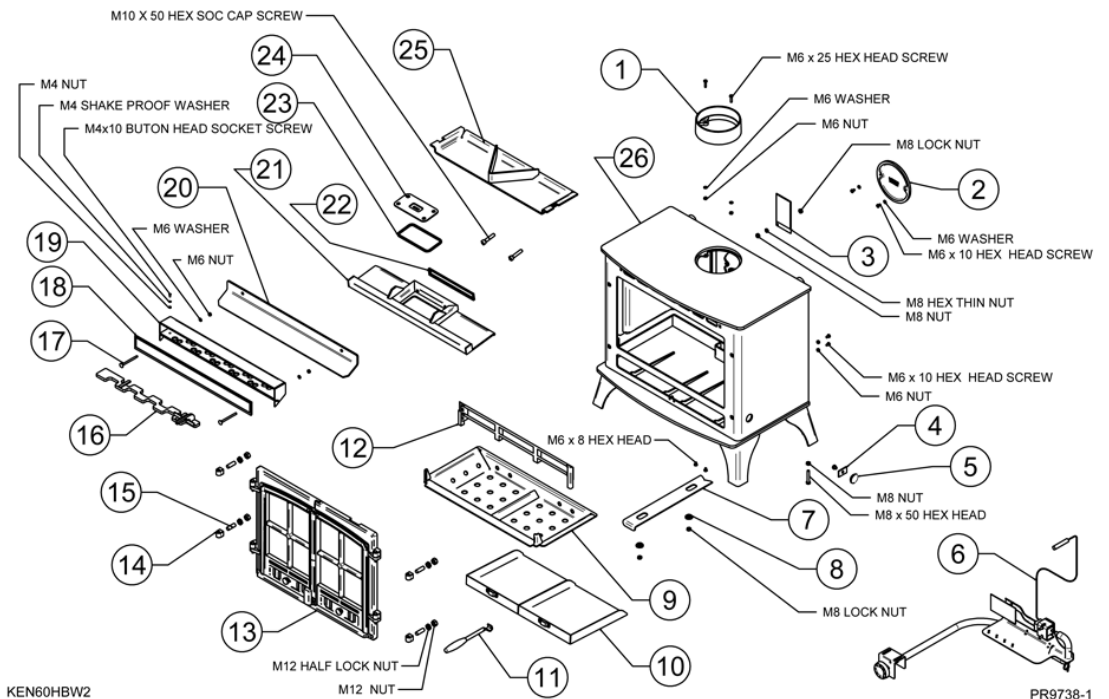

KEN60HBW2

PR9738-1



Due to continual technical improvements please check online or with your Kensal retailer for the most up to date parts lists.

Only use Genuine Kensal spares when servicing your appliance.

Basic Spare Parts

TYPICAL DOOR ASSEMBLY

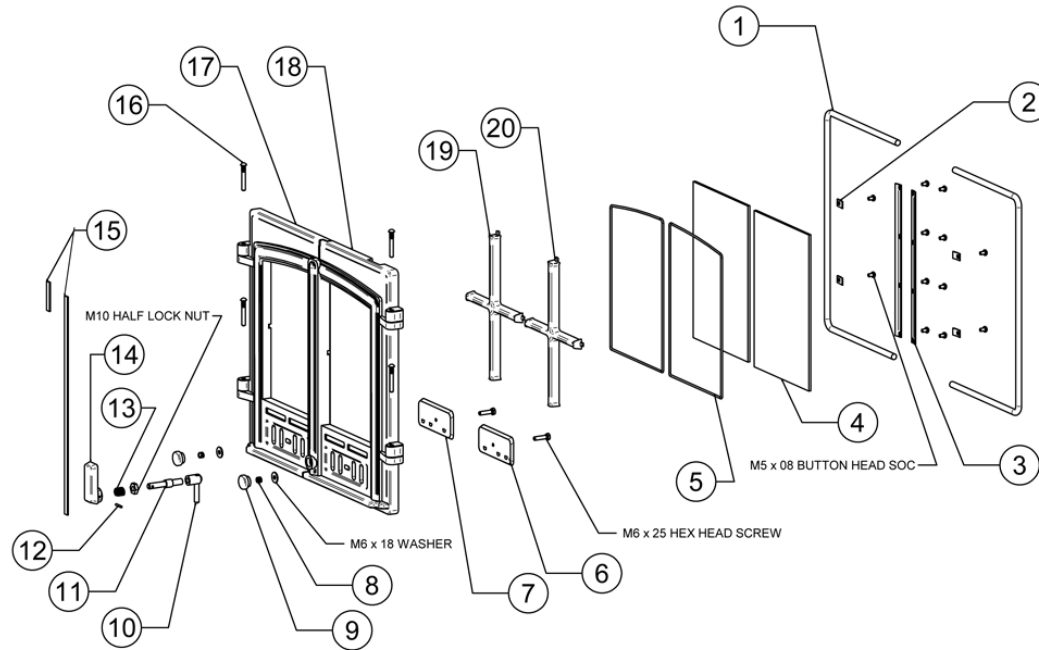

Ref. No.	Description
1	ø13 ROUND BLACK ROPE
2	THIN GLASS CLIP
3	GLASS FIXING CLIP
4	DOOR GLASS
5	ø3 ROUND BLACK ROPE
6	PRIMARY AIR SLIDER RH
7	PRIMARY AIR SLIDER LH
8	PRIMARY AIR SLIDER SPRING
9	PRIMARY KNOB
10	2 DOOR SPINDLE CATCH BLOCK ASSEMBLY
11	DOOR SPINDLE
12	SPIROL PIN
13	SPRING
14	KNOB 'A'
15	FLAT BLACK ROPE
16	HINGE PIN
17	DOOR LH
18	DOOR RH
19	GLAZING BAR LH
20	GLAZING BAR RH

KEN40HBW2 / KEN 40HBMF2 /KEN60HBW2 / KEN 60HBMF2

PR9739-1

KENSAL 40 - RIDDLING ASSEMBLY

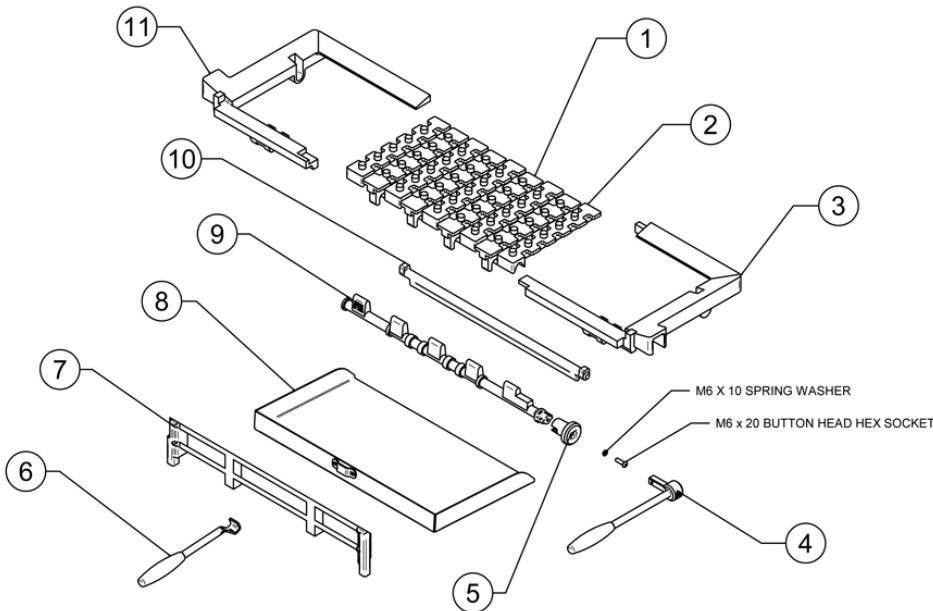

Ref.	Description
1	FIXED GRATE BAR
2	RIDDLING GRATE BAR
3	R/H INFILL
4	RIDDLING TOOL
5	RIDDLING SOCKET
6	ASHPAN TOOL
7	LOG GUARD
8	ASHPAN
9	RIDDLING BAR
10	BACK RIDDLING BAR
11	L/H INFILL

KEN40HBMF2

PR9745-1



Due to continual technical improvements please check online or with your Kensal retailer for the most up to date parts lists.

Only use Genuine Kensal spares when servicing your appliance.

Service Records

1ST SERVICE

Date of Service:.....

Next Service Due:.....

Signed:.....

Retailer's Stamp/HETAS Registration Number

2ND SERVICE

Date of Service:.....

Next Service Due:.....

Signed:.....

Retailer's Stamp/HETAS Registration Number

3RD SERVICE

Date of Service:.....

Next Service Due:.....

Signed:.....

Retailer's Stamp/HETAS Registration Number

4TH SERVICE

Date of Service:.....

Next Service Due:.....

Signed:.....

Retailer's Stamp/HETAS Registration Number

5TH SERVICE

Date of Service:.....

Next Service Due:.....

Signed:.....

Retailer's Stamp/HETAS Registration Number

6TH SERVICE

Date of Service:.....

Next Service Due:.....

Signed:.....

Retailer's Stamp/HETAS Registration Number

7TH SERVICE

Date of Service:.....

Next Service Due:.....

Signed:.....

Retailer's Stamp/HETAS Registration Number

8TH SERVICE

Date of Service:.....

Next Service Due:.....

Signed:.....

Retailer's Stamp/HETAS Registration Number

9TH SERVICE

Date of Service:.....

Next Service Due:.....

Signed:.....

Retailer's Stamp/HETAS Registration Number

10TH SERVICE

Date of Service:.....

Next Service Due:.....

Signed:.....

Retailer's Stamp/HETAS Registration Number



HETAS Approval

These appliances have been approved by HETAS as an intermittent operating appliance for burning manufactured briquette smokeless fuels.

KENSAL

Gazco Limited, Osprey Road, Sowton Industrial Estate, Exeter, Devon, England EX2 7JG

Tel: (01392) 261999 Fax: (01392) 444148 E-mail: info@gazco.com

A member of the Stovax Group

E & O E